

Rittal – The System.

Faster – better – everywhere.

TopTherm Chiller



3318.XXX
3319.XXX
3320.XXX
3334.XXX
3360.XXX

Assembly and operating instructions

ENCLOSURES

POWER DISTRIBUTION

CLIMATE CONTROL

IT INFRASTRUCTURE

SOFTWARE & SERVICES

FRIEDHELM LOH GROUP



Contents

EN

Contents

1	Notes on documentation	3	6.3	Commissioning procedure	29
1.1	Other applicable documents	3	6.4	Bleeding the cooling medium pump	30
1.2	CE conformity	3	7	Operation	31
1.3	Retention of documents	3	7.1	Control components	31
1.4	Symbols used	3	7.2	Key functions	31
2	Safety notes	4	7.2.1	Key functions during operation	31
2.1	Risks in case of failure to observe the safety instructions	4	7.2.2	Key functions during parameter adjustment	31
2.2	Safety instructions for assembly, inspection and maintenance work	4	7.3	Fixed value control or combined control	32
2.3	Unauthorised operation	4	7.4	Meaning of the control parameters	33
2.4	Health risks due to the refrigerant R134a and the cooling medium	4	7.5	Meaning of the error codes	35
2.5	First aid measures	4	7.6	Alarm relay function	39
2.6	Fire-fighting measures	4	7.7	PLC outputs	39
2.7	Safety measures and equipment	4	7.8	Setting the digital real-time clock	39
2.8	Potential hazards and how to avoid them	5	8	Inspection and maintenance	40
3	Device description	7	8.1	Maintaining the refrigerant circuit	40
3.1	General functional description	9	8.2	Cooling medium	40
3.2	Control	10	8.2.1	General remarks	40
3.3	Characteristic curves	10	8.2.2	Cooling medium requirements	40
3.3.1	Characteristic curves of pump	10	8.2.3	Preparation and care	41
3.3.2	Performance diagrams	11	8.2.4	Recommended "Cooling medium for chillers"	41
3.4	Safety devices	11	8.2.5	Monitoring the cooling medium	42
3.5	Filter mats (accessories)	12	8.3	Cleaning the condenser	42
3.6	Proper usage	12	8.4	Cleaning the filter mat (accessories)	43
3.7	Scope of supply	12	8.5	Draining the cooling medium tank	43
4	Transportation	14	9	Troubleshooting	44
5	Assembly and connection	15	10	Decommissioning and disposal	45
5.1	Dimensions	15	10.1	Decommissioning	45
5.1.1	Dimensions 3318.600, 3318.610 and 3319.600, 3319.610	15	10.2	Disposal	45
5.1.2	Dimensions 3320.600 and 3334.600	16	11	Accessories	46
5.1.3	Dimensions 3334.660	17	11.1	Connection set for air/water heat exchangers	46
5.1.4	Dimensions 3360.100	18	11.2	Flow regulator valve	46
5.1.5	Dimensions 3360.250	19	11.3	Metal filter (aluminium filter)	46
5.1.6	Dimensions 3360.470	20	11.4	Cooling medium for chillers (ready-mix)	46
5.1.7	Assembling the chiller for wall mounting (3360.xxx)	21	11.5	Levelling feet	47
5.2	Installation site requirements	23	11.6	Twin castors	47
5.3	Installing the chiller	24	12	Appendix	48
5.4	Making the hydraulic connection	24	12.1	P+ID diagram	48
5.5	Making electrical connection	24	12.2	Electrical circuit diagram	56
5.5.1	Connecting the power supply	25	12.3	Spare parts	60
5.5.2	Connecting the alarm relay query device	25	12.4	Technical specifications	64
5.5.3	External activation	25			
5.5.4	Connecting the chiller to the PLC	25			
5.6	Room temperature sensor (option)	27			
5.7	Installing the filter mats (accessories)	27			
5.8	Setting the filter mat monitor	28			
6	Commissioning	29			
6.1	Cooling medium	29			
6.2	Filling the cooling medium	29			

1 Notes on documentation

These instructions are aimed at installers and operators who are familiar with the installation and the operation of the chiller. It is very important to read and follow these operating instructions prior to commissioning. The manufacturer will not accept any liability for damage or operating problems resulting from failure to observe these operating instructions.

1.1 Other applicable documents

In conjunction with these instructions the flow diagram and electrical wiring diagram for the related model apply (see section 12 "Appendix").

1.2 CE conformity

The declaration of conformity is included in the appendix of these installation and operating instructions.

1.3 Retention of documents

These instructions and all associated documents constitute an integral part of the product. They must be supplied to the operator. The operator is responsible for storage of the documents so they are readily available when needed.

1.4 Symbols used

Please observe the following safety instructions and other notes in this guide:

Safety and other notes:



Danger!
Immediate danger to life and limb!



Risk of burns!
Risk of injury due to contact with hot surfaces or hot fluids!



Danger!
Risk of injury due to contact with cold surfaces!



Risk of cuts!
Risk of injury on touching the fins on the condenser!



Danger!
Danger of death due to electric shock!



Caution!
Explosion hazard!



Caution!
Potential threat to the product and the environment.



Note:
Useful information and special features.

Symbol identifying required actions:

- The bullet point indicates an action to be performed.

2 Safety notes

Please observe the following general safety notes when operating and installing the chiller:

- Assembly, installation and maintenance must only be carried out by qualified personnel.
- Only use original spare parts and accessories authorised by the manufacturer to ensure the protection and safety of the chiller. The usage of other parts will render any liability void.
- Do not make any changes to the chiller that have not been agreed with and approved by the manufacturer.
- It is also imperative that you observe the special safety instructions for the individual activities in the individual chapters.

2.1 Risks in case of failure to observe the safety instructions

In case of failure to observe the safety notes, people, the environment and the chiller may be placed at risk. Failure to comply with the safety notes makes all claims for compensation void.

2.2 Safety instructions for assembly, inspection and maintenance work

- The installation, commissioning and servicing of the chiller must be carried out in strict compliance with the technical documentation for the chiller and in such a way that no potentially hazardous situations are allowed to occur.
- Cleaning and maintenance work on the chiller must only be performed with the unit shut down. For this purpose, it is vital to ensure that the chiller is disconnected from the power supply and is secured against switching back on. It is imperative that you observe the procedure for shutting down the chiller described in the operating instructions.
- All safety devices and protective equipment must be reattached or put in a functional condition immediately after the work is complete.
- Modifications or changes to the chiller are not allowed.
- Only appropriately qualified personnel as defined by BGR500 chap. 2.35 / EN 378 are allowed to work on the refrigerant circuit.
- Do not install the chiller without protection outside of covered areas, or in an explosive or aggressive environment.
- Do not install the chiller on an unstable surface or a surface that is not designed for the weight of the chiller.
- Do not bypass any electrical safety devices to make it possible to operate the chiller.

2.3 Unauthorised operation

The safety of the chiller supplied is only ensured if it is used properly (see section 3.6 "Proper usage"). Under no circumstances should the limit values specified in the technical data be exceeded.

The chiller is not allowed to be used for the direct cooling of liquids that are used for foodstuffs (e.g. drinking water).

Any existing contact hazard protection for moving parts must not be removed from chillers while operational. Hazards due to electrical power, do not remove any switch box cover!



Explosion hazard!

The use of the chiller for cooling inflammable or pyrophoric substances is prohibited.

2.4 Health risks due to the refrigerant R134a and the cooling medium

The refrigerant changes status during operation and becomes pressurised. The R134a safety data sheet must be observed.

The cooling medium (additive) is a liquid. We suggest: "Cooling medium for chillers" (see section 6.1 "Cooling medium"). The safety data sheet "Cooling medium for chillers" must be observed.

2.5 First aid measures

Please refer to safety data sheets R134a and "Cooling medium for chillers".



Note:

Safety data sheets are available for downloading at www.rittal.com.

2.6 Fire-fighting measures

Suitable extinguishing agent











All known extinguishing agents can be used.

2.7 Safety measures and equipment

- Ensure adequate ventilation.
- Hand protection: Safety gloves.
- Eye protection: Safety goggles.
- Body protection: Wear safety shoes when handling pressurised gas bottles.

2.8 Potential hazards and how to avoid them







The following table provides an overview of other potential sources of danger and how to avoid them.

Location	Hazard		Cause	Precautionary measures
Device exterior: Louvred condenser	Minor cuts		Accidental contact or contact while installing the air filter (option, see section 5.7 "Installing the filter mats (accessories)")	Wear safety gloves.
Device exterior: Area around the chiller	Major burns		Fire caused by short-circuiting or overheating of the electricity supply line to the chiller	Ensure that the cable cross-section and electricity supply line comply with the valid regulations.
Device exterior	Cuts		Contact with fan wheel	Do not remove the protective cover around the fan wheel.
Device interior: Hot or cold parts	Burns / frostbite	 	Contact with parts with a high or low surface temperature.	The chiller may only be opened by trained, qualified personnel.
Device interior	Explosion		Soldering work inside the chiller may lead to an explosion due to the installed cooling circuit.	Maintenance may only be carried out by specialist personnel. Before carrying out soldering work on the cooling circuit or in its immediate vicinity, the refrigerant should be drained from the chiller.
Device exterior: Chiller with wheels	Personal injury or damage to property		The chiller starts to move due to unevenness of the floor surface.	If the recooling system is equipped with wheels (option), they must be locked with brakes while operational.
Device exterior	Severe personal injury or damage to property		The floor on which the chiller is installed is unstable and unable to support its weight. The chiller tips over or the floor gives way.	The weight of the chiller is shown on the rating plate. Additionally, please allow for the weight of the liquid in the tank (the tank capacity volume is shown on the rating plate) and make sure that the floor is suitable for installation purposes.
Device interior: Cooling medium circuit	Fungus and algae formation		Use of pure water as a cooling medium or refrigerant.	Use a water-glycol mixture as your cooling medium. Rittal recommends the use of "Cooling medium for chillers" (ready-mix). Further information may be found in sections 6–8.
Device interior: Cooling medium circuit	Personal injury or damage to property		Hazard due to pressure	Recurrent function test of pressure switch

Tab. 1: Hazards and precautionary measures

2 Safety notes

EN

Location	Hazard		Cause	Precautionary measures
Device exterior	Personal injury or damage to property		Displacement of oxygen due to escape of larger amounts of refrigerants If refrigerant escapes, poisonous gases may be generated under the effect of flames.	Recurrent leak test. Operation of cap valves by cooling technology experts or service companies only.
	Risk for the environment		Risk for the environment due to escape of refrigerant	
Device interior	Personal injury or damage to property		Electrical hazard while working on the chiller	The power to the chiller must be disconnected via the main switch.
Device exterior	Personal injury or damage to property		Hazards when transporting or assembling the chiller	Secure the chiller against any risk of tilting (eyebolts) when transporting or assembling.
Device interior	Severe personal injury or damage to property		Hazard due to electrical equipment of the chiller	Recurrent testing of electrical equipment (Germany BGV A3)
Device interior	Risk for the product		Liquid level after transport not in upright position	Only transport the chiller upright. Should the chiller be tilted during transportation, please wait some minutes before switching on again.

Tab. 1: Hazards and precautionary measures



Note:

Specialist personnel are individuals who, by virtue of their training, education, experience and knowledge of the relevant provisions, regulations and measures for accident prevention and relating to the operating conditions, have been authorised by the owner or responsible individual to ensure the safety of the system, carry out all essential tasks, and are therefore in a position to identify and avert all potential threats.

3 Device description

Chillers are used for the central and economical cooling and supply of a cooling medium (water + glycol, see section 8.2 "Cooling medium") in the event of physical separation between the place where cooling is required and the refrigeration. The cooling medium is supplied using a pipe system.

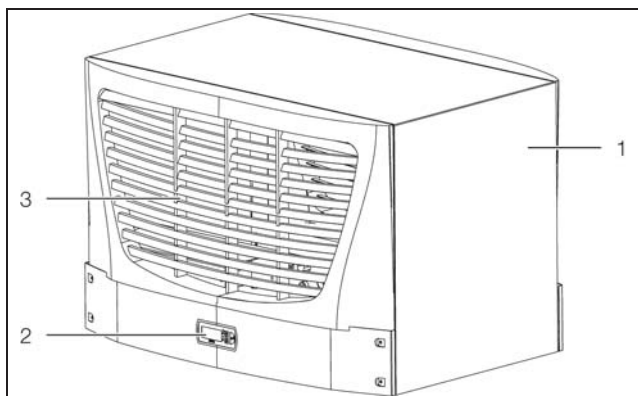

Fig. 1: View from front (3318.600, 3318.610, 3319.600, 3319.610)

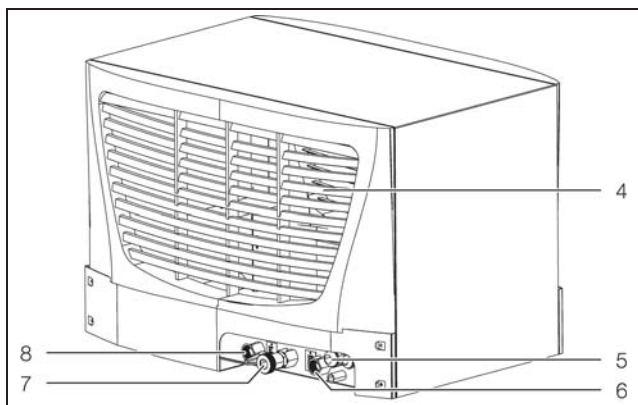

Fig. 2: View from rear (3318.600, 3318.610, 3319.600, 3319.610)



Note:

Tank drain nozzle (see fig. 2, item 7) only on models 3318.600 and 3319.600.

Key to figures 1 and 2

- 1 Rating plate
- 2 Display
- 3 Louvred grille for air inlet
- 4 Louvred grille for air outlet
- 5 Cable gland
- 6 Cooling medium outlet
- 7 Tank drain nozzle
- 8 Cooling medium return

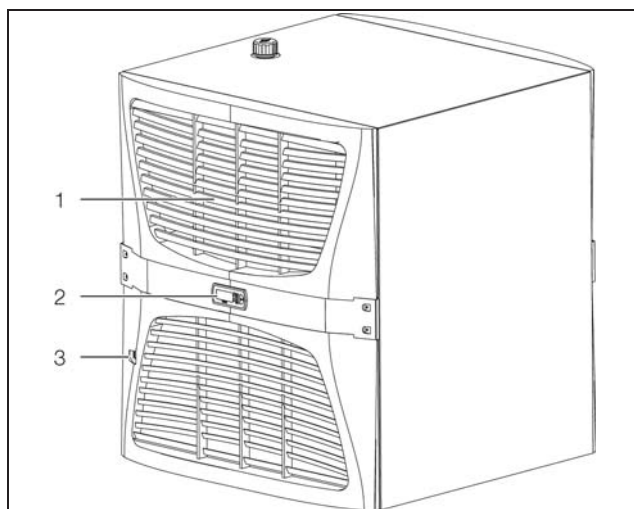

Fig. 3: View from front (3320.600, 3334.600)

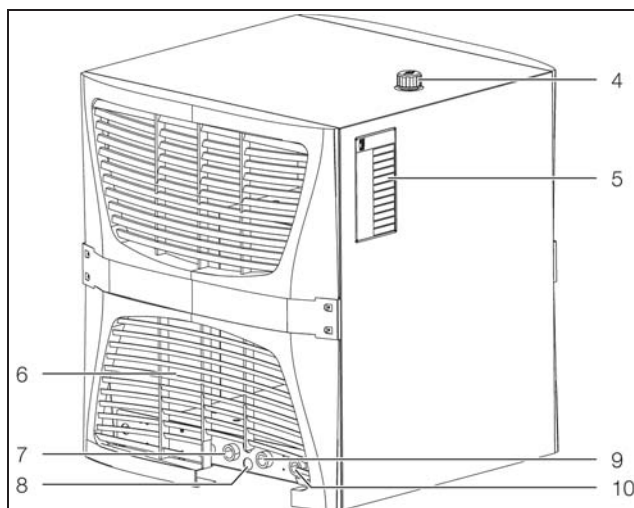

Fig. 4: View from rear (3320.600, 3334.600)

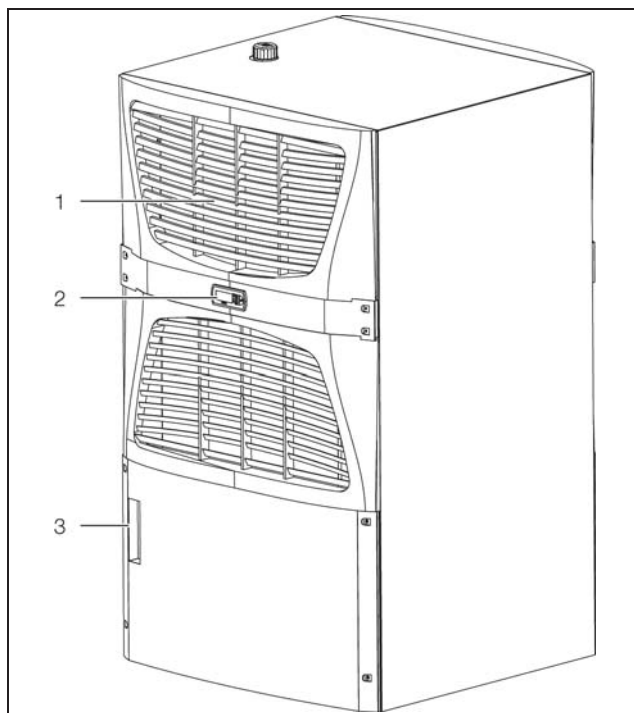

Fig. 5: View from front (3334.660)

3 Device description

EN

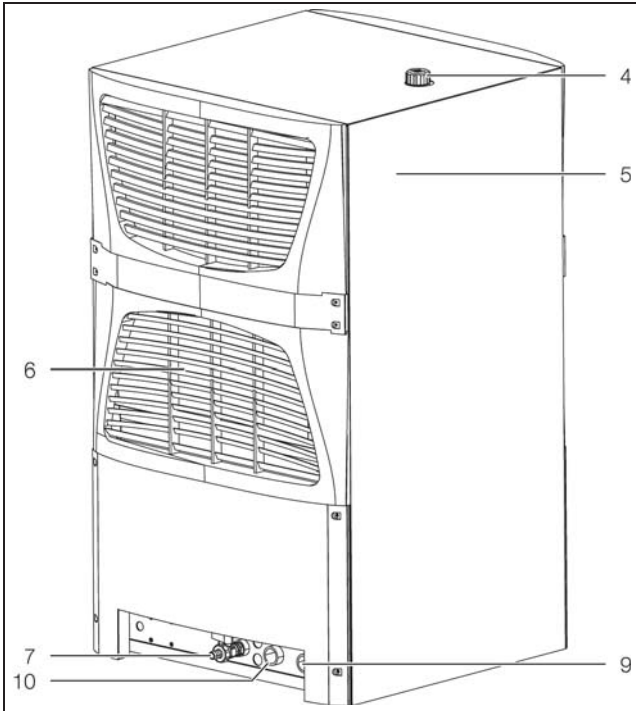

Fig. 6: View from rear (3334.660)

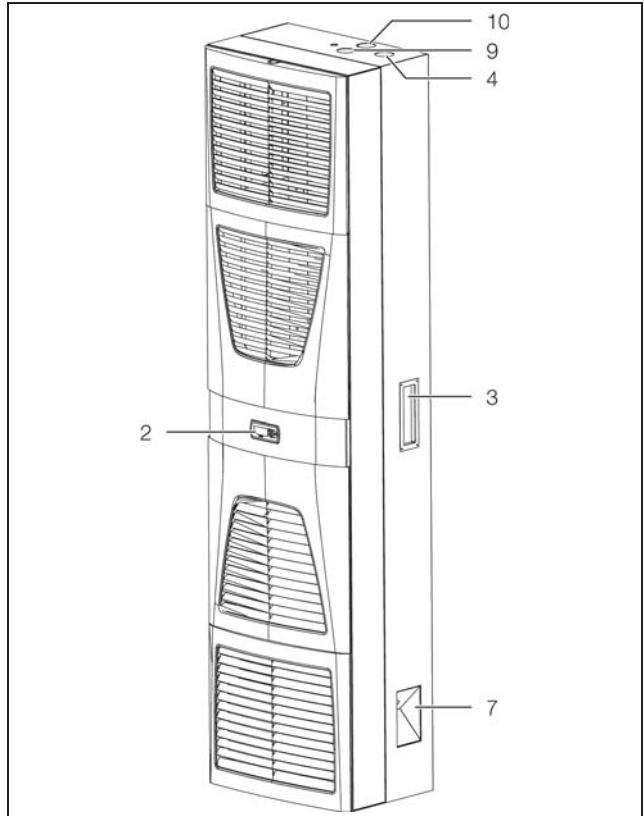

Fig. 8: View from front (3360.250)

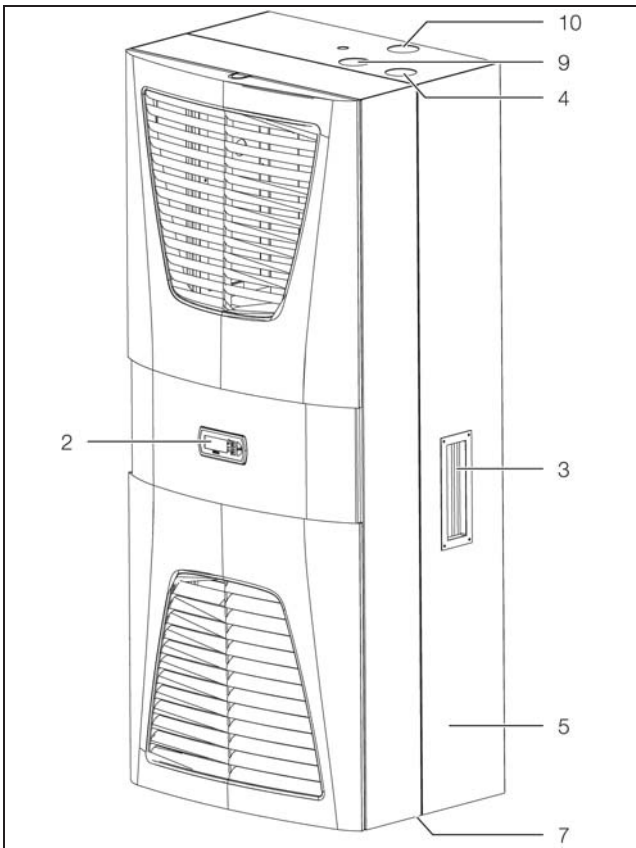

Fig. 7: View from front (3360.100)

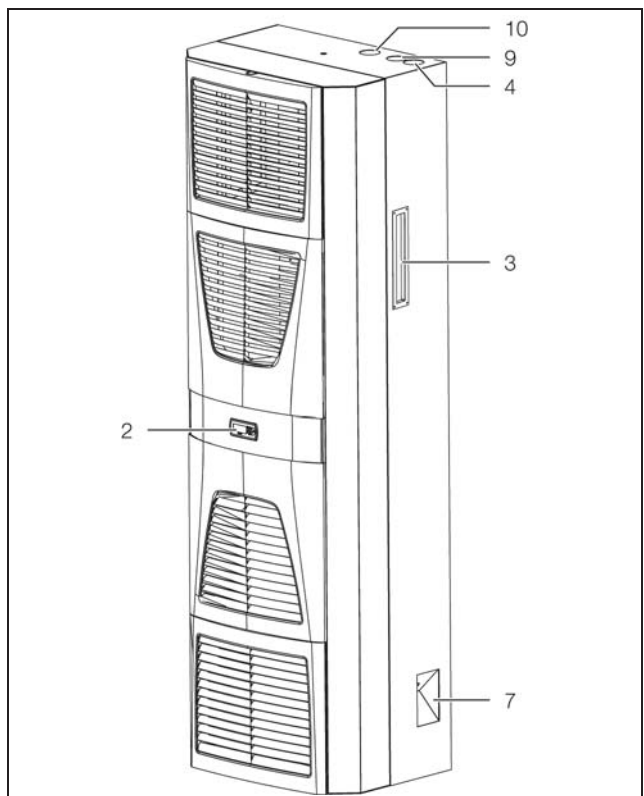

Fig. 9: View from front (3360.470)

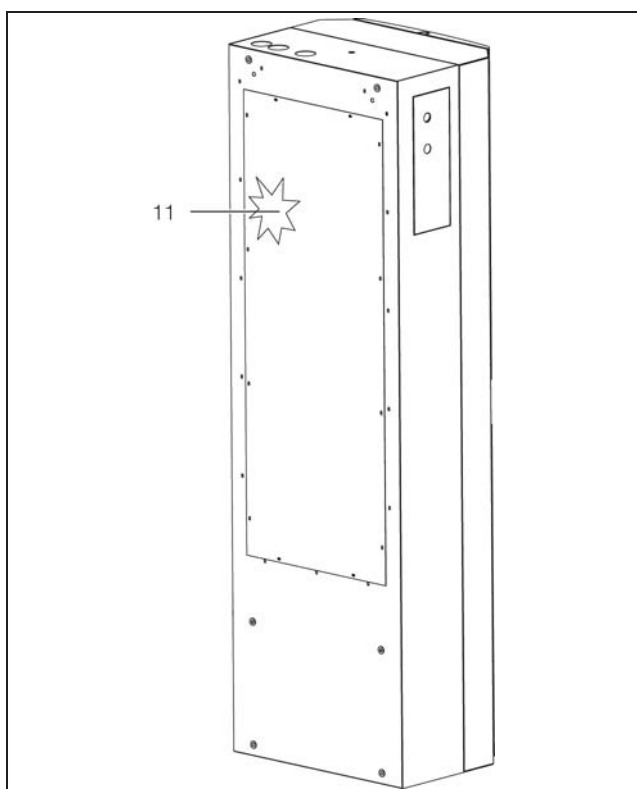

Fig. 10: Motor circuit-breaker (3360.470)

Key to figures 3 to 10

- 1 Louvred grille for air outlet (two-part)
- 2 Display
- 3 Liquid level display of cooling medium
- 4 Tank filling nozzle for cooling medium
- 5 Rating plate
- 6 Louvred grille for air inlet (two-part)
- 7 Tank drain nozzle
- 8 Cable gland
- 9 Cooling medium inlet
- 10 Cooling medium return
- 11 Motor circuit-breaker



Note:

You reach the motor circuit breaker of the medium pump on model 3360.47x by opening the service flap and the underlying control box. See also F1 in section 12.2 "Electrical circuit diagram".

The chillers are equipped with an open reservoir for the cooling medium. Only chiller models 3318.600 and 3319.600 have a closed cooling medium circuit, 2.5 bar. For the closed chillers, we recommend the installation of a pressure manometer, 0 – 6 bar, in the cooling medium circuit.

3.1 General functional description

The chiller comprises four main components (see fig. 11):

- Evaporator coil (item 12),
 - refrigerant compressor (item 13),
 - condenser (item 1) with fan (item 2),
 - control or expansion valve (item 4),
- which are connected together by pipes. A pressure switch (item 14) limits the maximum pressure in the refrigerant circuit. The refrigerant R134a (CH_2FCF_3) is chlorine-free. Its Ozone Depletion Potential (ODP) is 0. A filter drier (item 3) which is integrated into the hermetically sealed refrigerant circuit provides effective protection against moisture, acid, dirt particles, and foreign bodies. A temperature control with temperature probe (item 6) ensures that the cooling medium is maintained at a preset setpoint temperature.

In the evaporator coil (item 12), the liquid refrigerant is converted to a gaseous state. The heat necessary for this purpose is taken from the cooling medium in the plate heat exchanger, which has the effect of cooling the cooling medium. The refrigerant is compressed in the compressor (item 13). As a result the refrigerant has a higher temperature than the ambient air.

This heat is dissipated to the ambient air over the surface of the condenser (item 1), resulting in the refrigerant liquefying again.

The refrigerant is injected into the evaporator (item 12) using a thermostatic expansion valve (item 4), as a result it is expanded and as a consequence can absorb the heat from the cooling medium (water or water-glycol mixture).

The cooling medium is pumped to the equipment in a closed circuit using a pump (item 9) and cooling medium tank (item 10). The flow monitor (item 11) ensures the evaporator (item 12) is protected against freezing if the flow rate is too low. The level switch (item 5, option) protects the pump (item 9) against dry running. The cooling medium (water or water-glycol mixture) feed temperature is regulated using the temperature probe (item 6) in the tank.

Flow diagrams for the individual unit types may be found in section 12 "Appendix".

3 Device description

EN

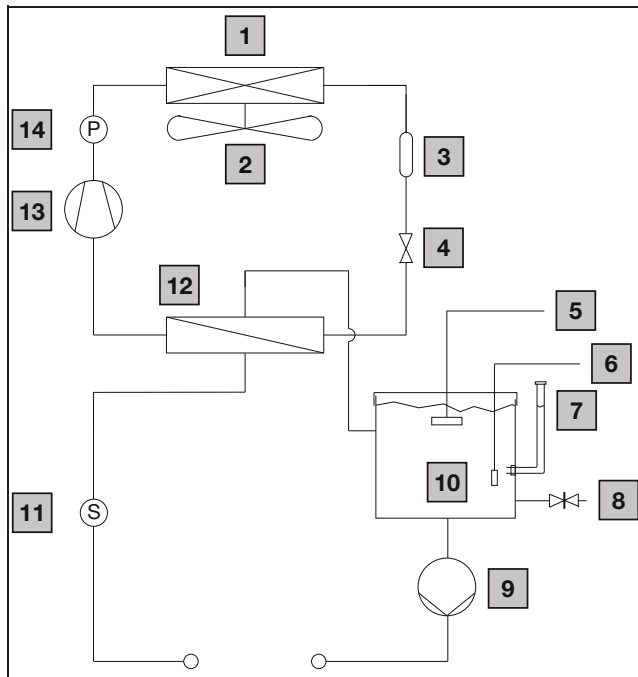

Fig. 11: Schematic diagram of refrigerant circuit (example, chiller with open refrigerant circuit)

Key

- 1 Condenser, air-cooled
- 2 Condenser fan
- 3 Filter dryer
- 4 Expansion valve
- 5 Water level switch (option)
- 6 Temperature sensor
- 7 Fill nozzle
- 8 Tank drain nozzle
- 9 Cooling medium pump
- 10 Cooling medium tank
- 11 Flow monitor
- 12 Evaporator (plate heat exchanger)
- 13 Compressor
- 14 Pressure-operated switch

3.2 Control

The chillers are fitted with a controller for setting the functions of the chiller. Operating states are displayed using a display unit and parameters can be set using buttons.

3.3 Characteristic curves

3.3.1 Characteristic curves of pump

Characteristic curves measured under the following conditions:

- Ambient temperature (T_a) = 32°C
- Medium temperature (T_w) = 18°C
- Cooling medium with 20% glycol

Key to figures 12 to 15

- 50 Hz standard pump
- 60 Hz standard pump
- - - 50 Hz reinforced pump (option)
- - - 60 Hz reinforced pump (option)
- P External static pressure [bar]
- Q Delivery flow [l/min]

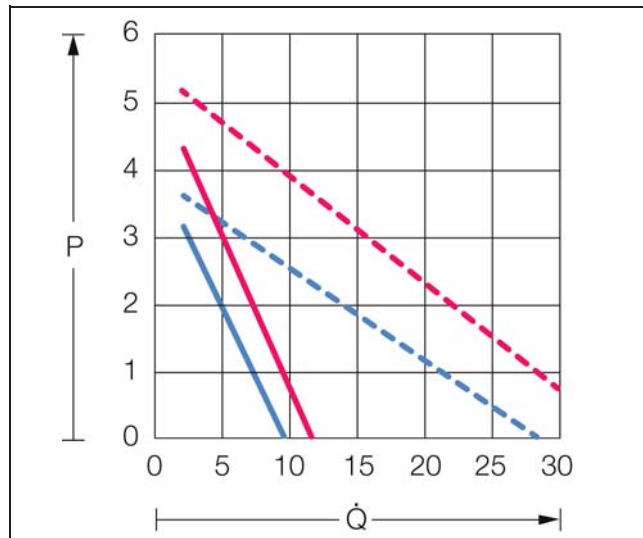

Fig. 12: Characteristic curve 3318.600, 3318.610, 3319.600, 3319.610

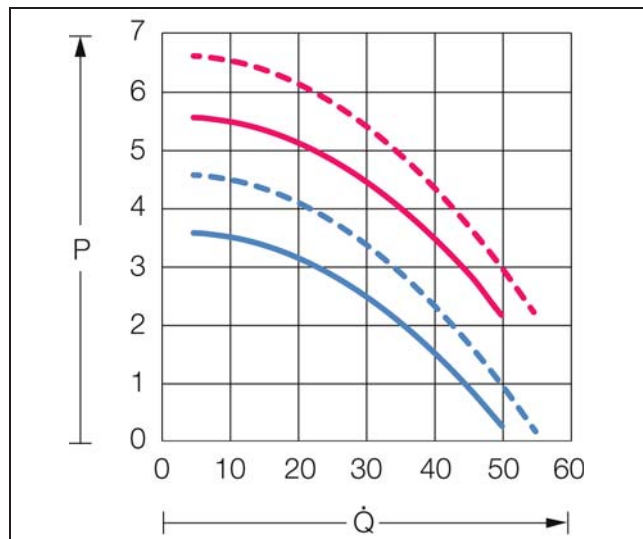

Fig. 13: Characteristic curve 3320.600, 3334.600, 3334.660

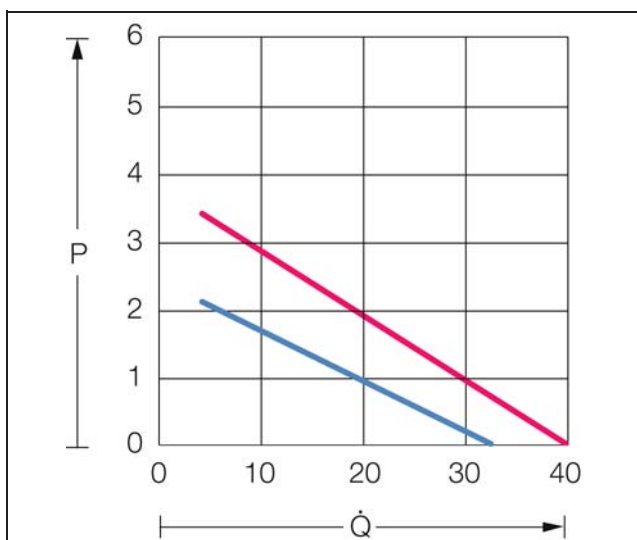

Fig. 14: Characteristic curve 3360.100, 3360.250

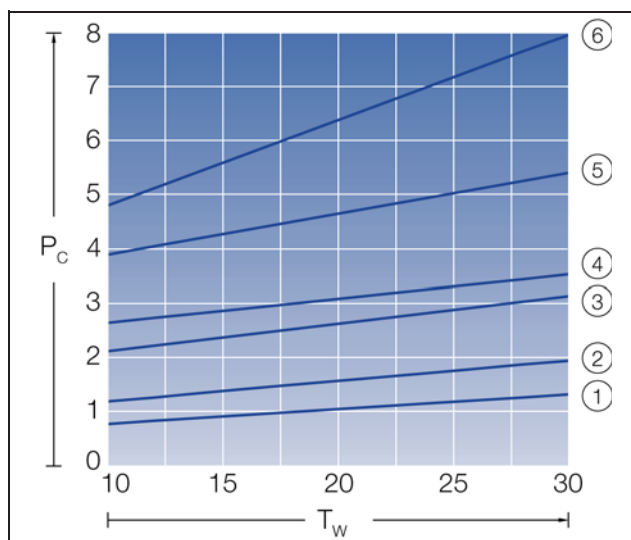

Fig. 16: Performance diagrams

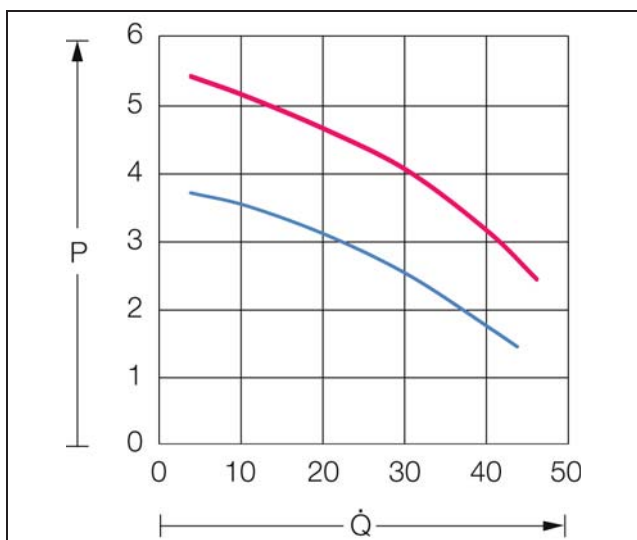

Fig. 15: Characteristic curve 3360.470

Types 3318.600, 3318.610, 3319.600, 3319.610

If the flow rate of the cooling medium is lower than 2 l/min the integrated flow switch switches. The unit does not start up.

Types 3320.600, 3334.600, 3334.660, 3360.100, 3360.250 and 3360.470

If the flow rate of the cooling medium is lower than 3 l/min the integrated flow switch switches. The unit does not start up.

3.3.2 Performance diagrams

Characteristic curves measured under the following conditions:

- Ambient temperature (T_a) = 32°C
- Frequency = 50 Hz
- For further performance diagrams, see Rittal chiller configurator

Key

- 1 Model 3318.600-610
- 2 Model 3319.600-610
- 3 Model 3320.250
- 4 Model 3320.600
- 5 Model 3334.600
- 6 Model 3334.660
- T_w Water inlet temperature [°C]
- P_c Total cooling output [kW]

3.4 Safety devices

- The chiller has a pressure switch in accordance with EN 12263, tested at component level, in the refrigerant circuit; this device is set to the maximum permissible pressure (PS).
- If there is a risk of icing of the evaporator, the compressor switches itself off and automatically switches itself back on again at higher temperatures.
- The refrigerant compressor motor, the fan motors and the pump are equipped with thermal winding protection switches against excess current and excess temperatures.
- To ensure that the compressor runs reliably and without problems (for example after reaching the setpoint temperature or after a fault), the compressor automatically switches back on after a delay of 180 seconds.
- The chiller has two integrated floating fault signal contacts (see circuit diagram for the relevant unit type in section 12.2 "Electrical circuit diagram"). Individual fault messages can be queried via an integrated Sub-D socket using an external PLC controller.

3 Device description

EN

3.5 Filter mats (accessories)

The chiller condenser is covered with a dirt-repelling, easy-to-clean RiNano coating. In many applications, therefore, the use of filter media is unnecessary, particularly with dry dusts.

For coarse dust and lint in the ambient air and/or air containing oil condensate, we recommend installing an additional metal filter mat (see section 11 "Accessories") in the chiller. The filter mats may be cleaned with suitable detergents and reused.

Automatic filter mat monitoring is built into the chillers (turned off by default). The monitoring device measures the dirt in the filter mat by comparing the ambient temperature and the air output temperature on the condenser. As the filter mat becomes increasingly dirty, the pressure in the refrigerant circuit rises and with it the temperature of the output air. This results eventually in a fault message.

3.6 Proper usage

The chillers have been developed and designed in accordance with the state of the art and the recognised rules governing safety. Nevertheless, if used improperly, they may pose a threat to life and limb or cause damage to property.

The chillers units described in these instructions must only be used for cooling water-glycol mixtures. When using other fluids, please refer to the technical specifications contained in the appendix, or contact the manufacturer. Under no circumstances should the limit values specified in the technical data be exceeded.



Explosion hazard!

The use of the chiller for cooling inflammable or pyrophoric substances is prohibited.

3.7 Scope of supply

The chiller is supplied in a packaging unit in a fully assembled state.

- Please check the scope of supply for completeness (tab. 2 to tab. 5).
- Check the packaging carefully for signs of damage. Traces of oil on damaged packaging, for example, may be an indication of refrigerant loss.



Note:

Any packaging damage may be the cause of a subsequent functional failure.

Qty.	Description
1	Chiller
1	Dispatch bag with
1	– Set of operating and installation instructions
1	– Eyebolt (M12)
4	– Threaded bolt (M6 x 30)
4	– Washer
4	– Nut (M6 x 5)

Tab. 2: Scope of supply – models 3318.600, 3318.610, 3319.600, 3319.610

Qty.	Description
1	Chiller
1	Dispatch bag with
1	– Set of operating and installation instructions
1	– Eyebolt (M12)

Tab. 3: Scope of supply – models 3320.600, 3334.600

Qty.	Description
1	Chiller
1	Dispatch bag with
1	– Set of operating and installation instructions
4	– Eyebolt (M8)

Tab. 4: Scope of supply – model 3334.660

Qty.	Description
1	Chiller
1	Dispatch bag with
1	– Set of operating and installation instructions
1	– Eyebolt (M12)
1	– Seal
1	– Cable tie
2	– Coupling (only 3360.100, .250)
1	– Tank drain nozzle

Tab. 5: Scope of supply – models 3360.100, 3360.250, 3360.470

Qty.	Description
10	– Nut
10	– Washer
10	– Threaded bolt

Tab. 5: Scope of supply – models 3360.100, 3360.250, 3360.470

4 Transportation

EN

4 Transportation

If the chiller is stored or transported at temperatures below freezing, you must completely drain the cooling medium circuit and flush it with a water-glycol mixture to prevent frost damage. This instruction also applies to the external condenser circuit for a water-cooled condenser (option).

- Only transport the chiller in its original packaging material before commissioning for the first time. In case of damage, inform the manufacturer without delay.
- When transporting the chiller, the weight specified on the rating plate must be taken into consideration.
- Use lifting gear with a suitable load capacity.
- Only transport the chiller upright.
- Only transport the chiller on the pallet supplied with the chiller or with the eyebolt provided (fig. 17, item 1).
- Prevent excessive vibration.
- If it is necessary to move the chiller in the factory, you must disconnect all connections on the chiller.
- Before transporting, empty the water circuit and tank (if applicable) (see section 8 "Inspection and maintenance").

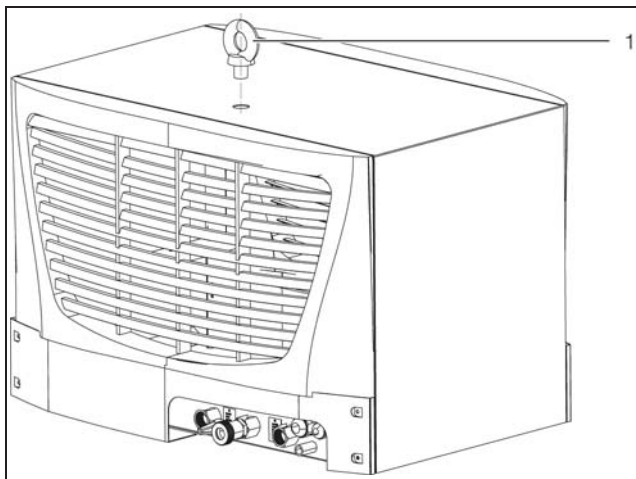

Fig. 17: Eyebolt for transportation (3318.600 shown here as an example)

5 Assembly and connection

5.1 Dimensions

5.1.1 Dimensions 3318.600, 3318.610 and 3319.600, 3319.610

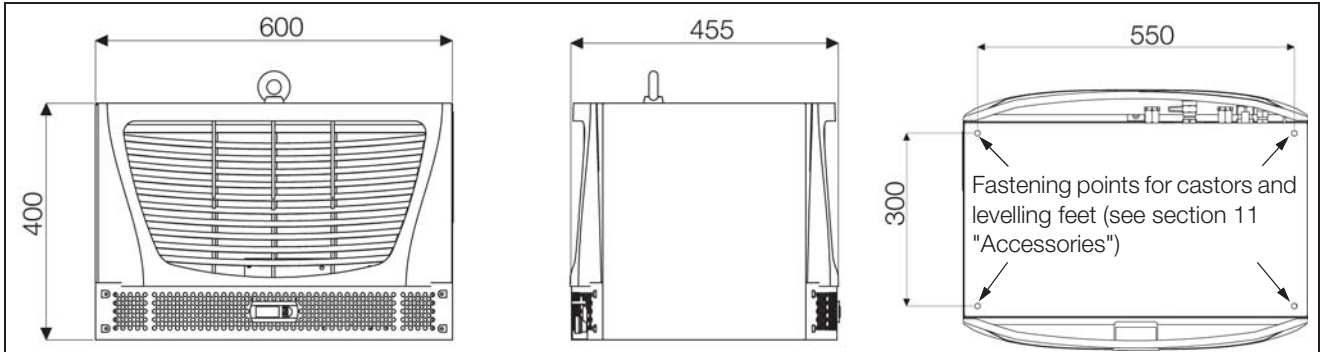

Fig. 18: Dimensions 3318.600, 3318.610 and 3319.600, 3319.610

5 Assembly and connection

EN

5.1.2 Dimensions 3320.600 and 3334.600

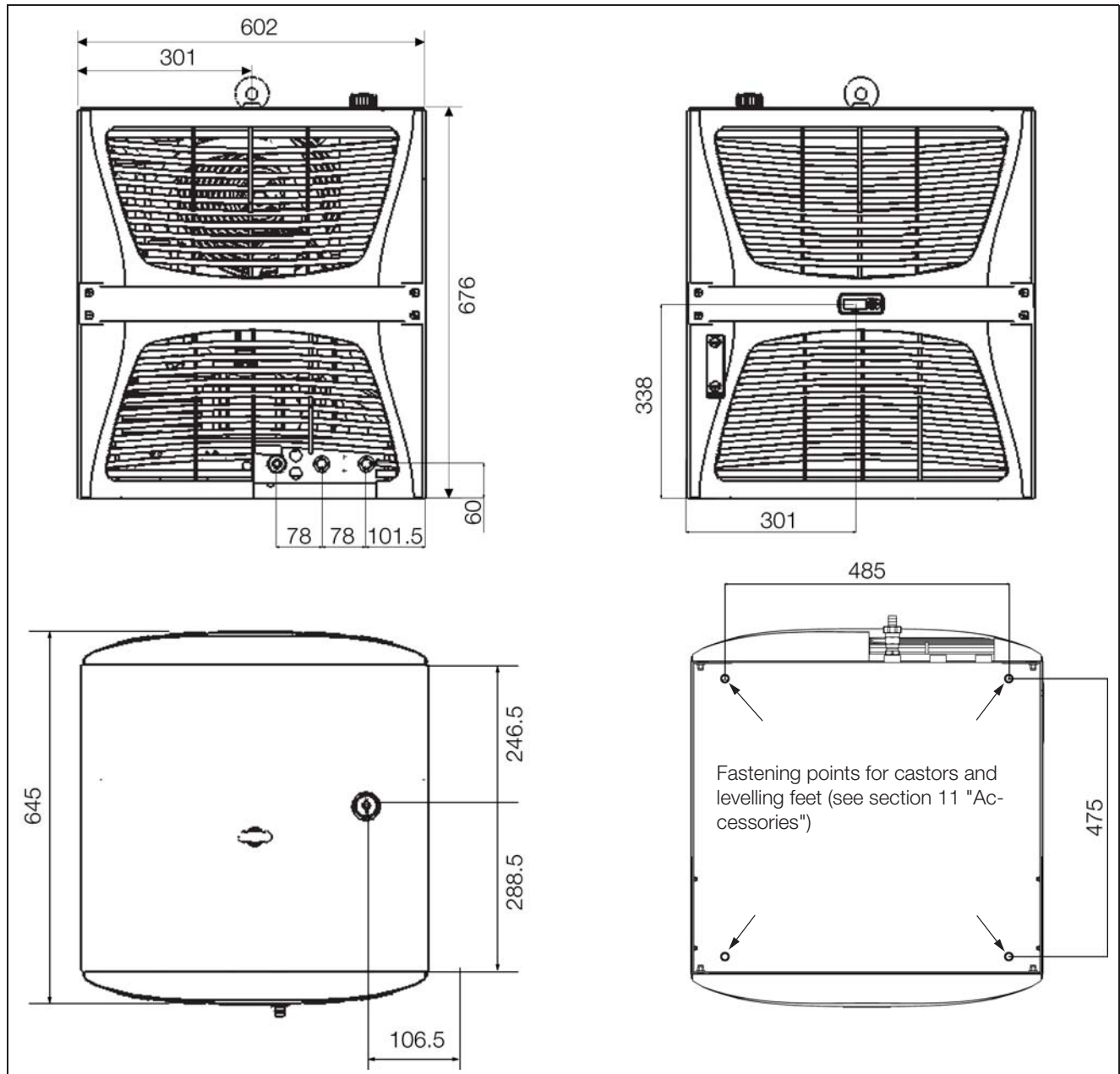

Fig. 19: Dimensions 3320.600 and 3334.600

5.1.3 Dimensions 3334.660

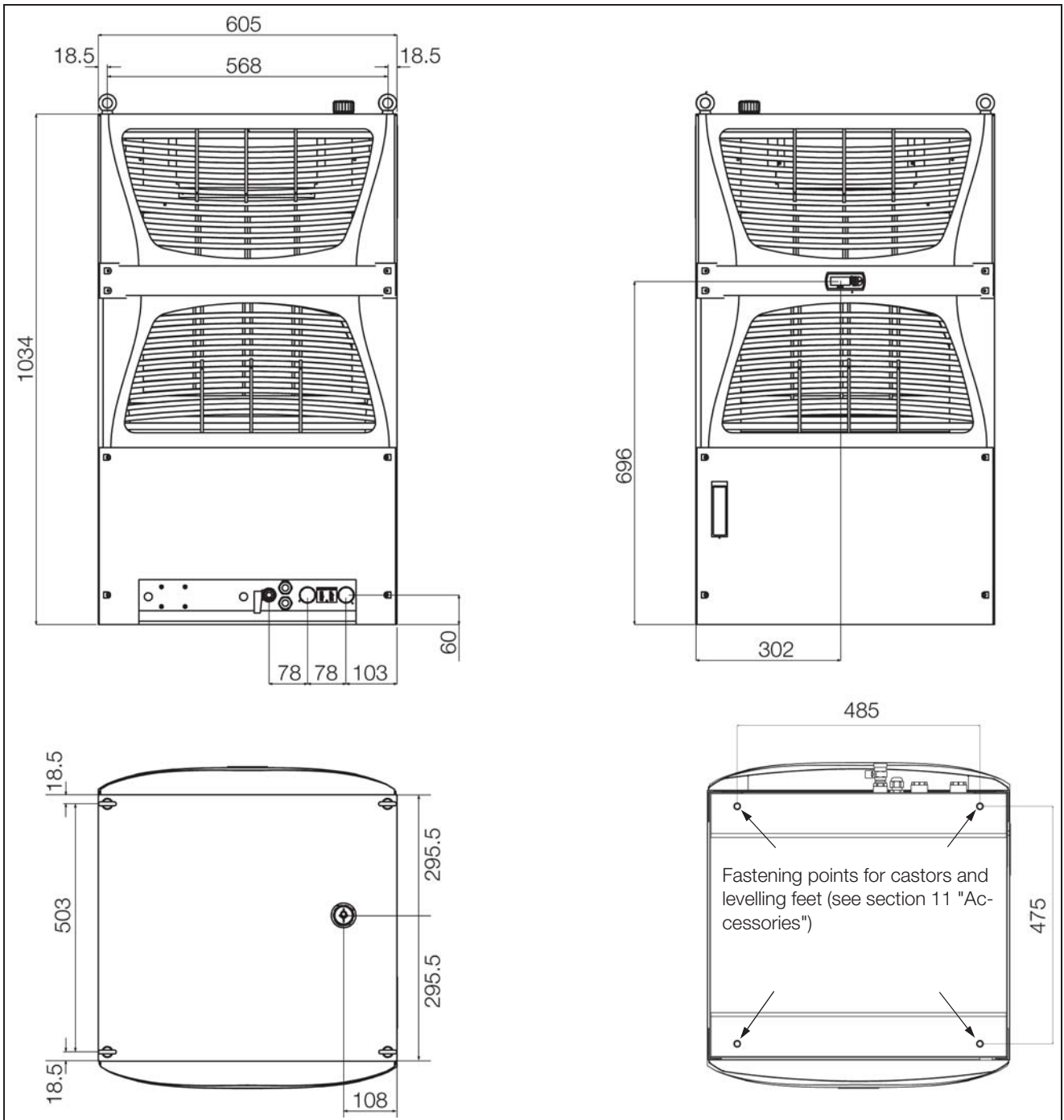

Fig. 20: Dimensions 3334.660

5 Assembly and connection

EN

5.1.4 Dimensions 3360.100

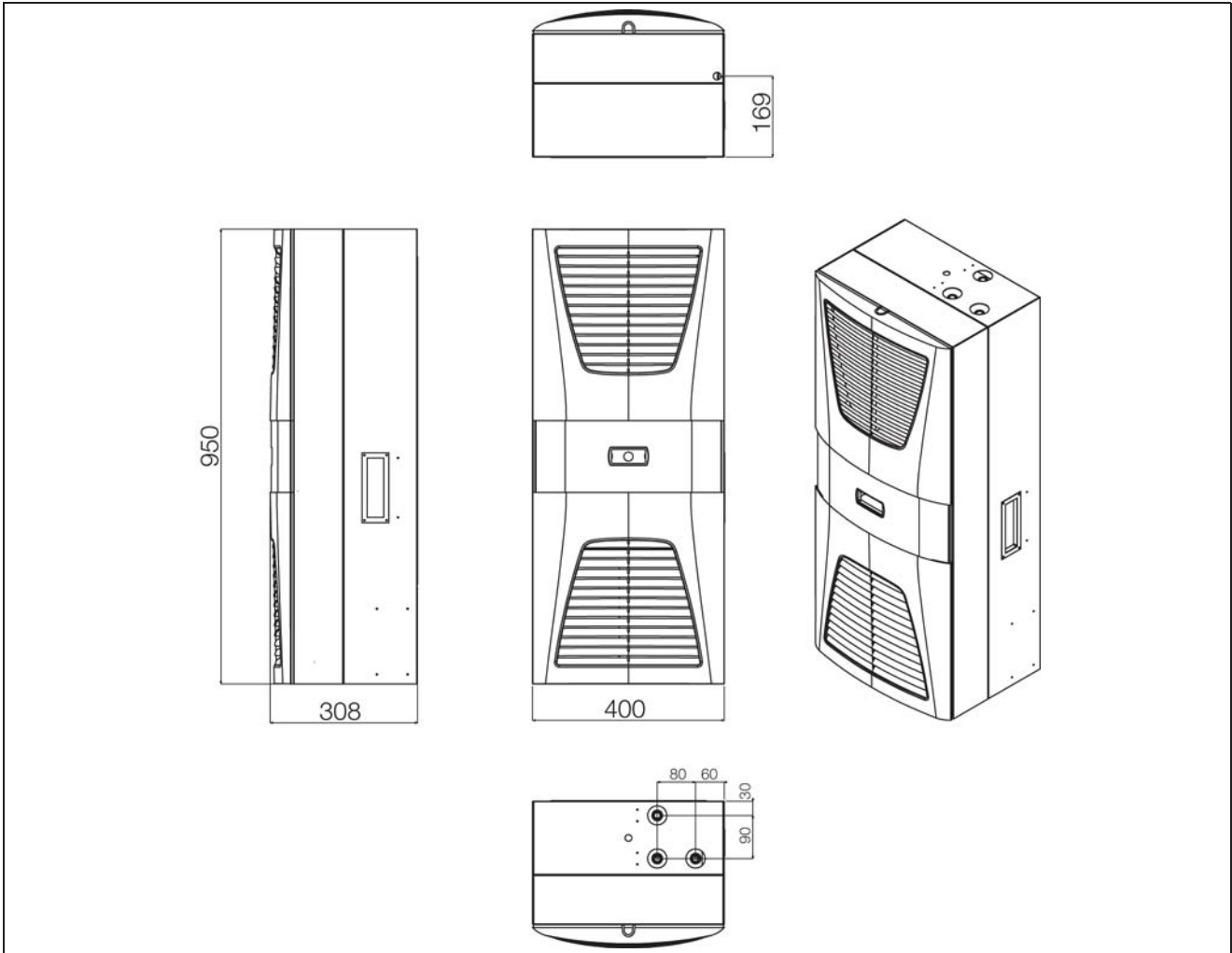

Fig. 21: Dimensions 3360.100

Mounting cut-out for external mounting/partial internal mounting/full internal mounting

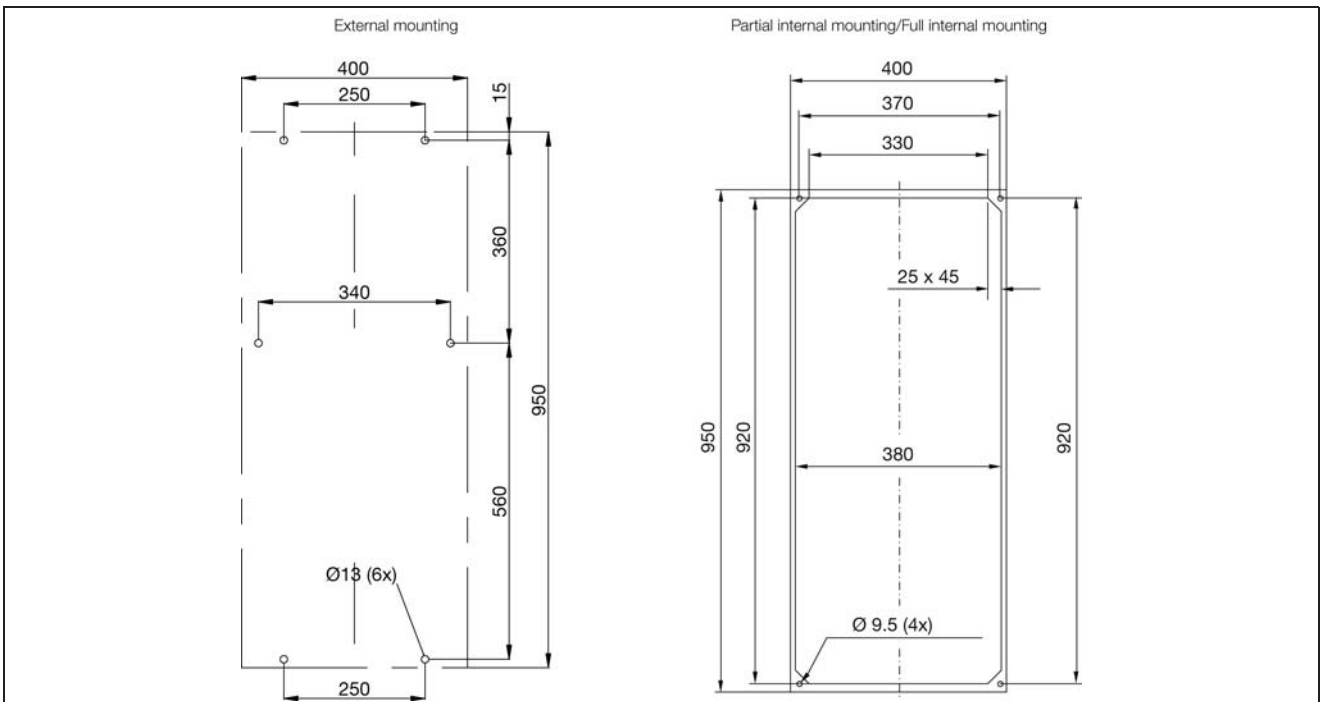

Fig. 22: Mounting cut-out for external mounting/partial internal mounting/full internal mounting

5.1.5 Dimensions 3360.250

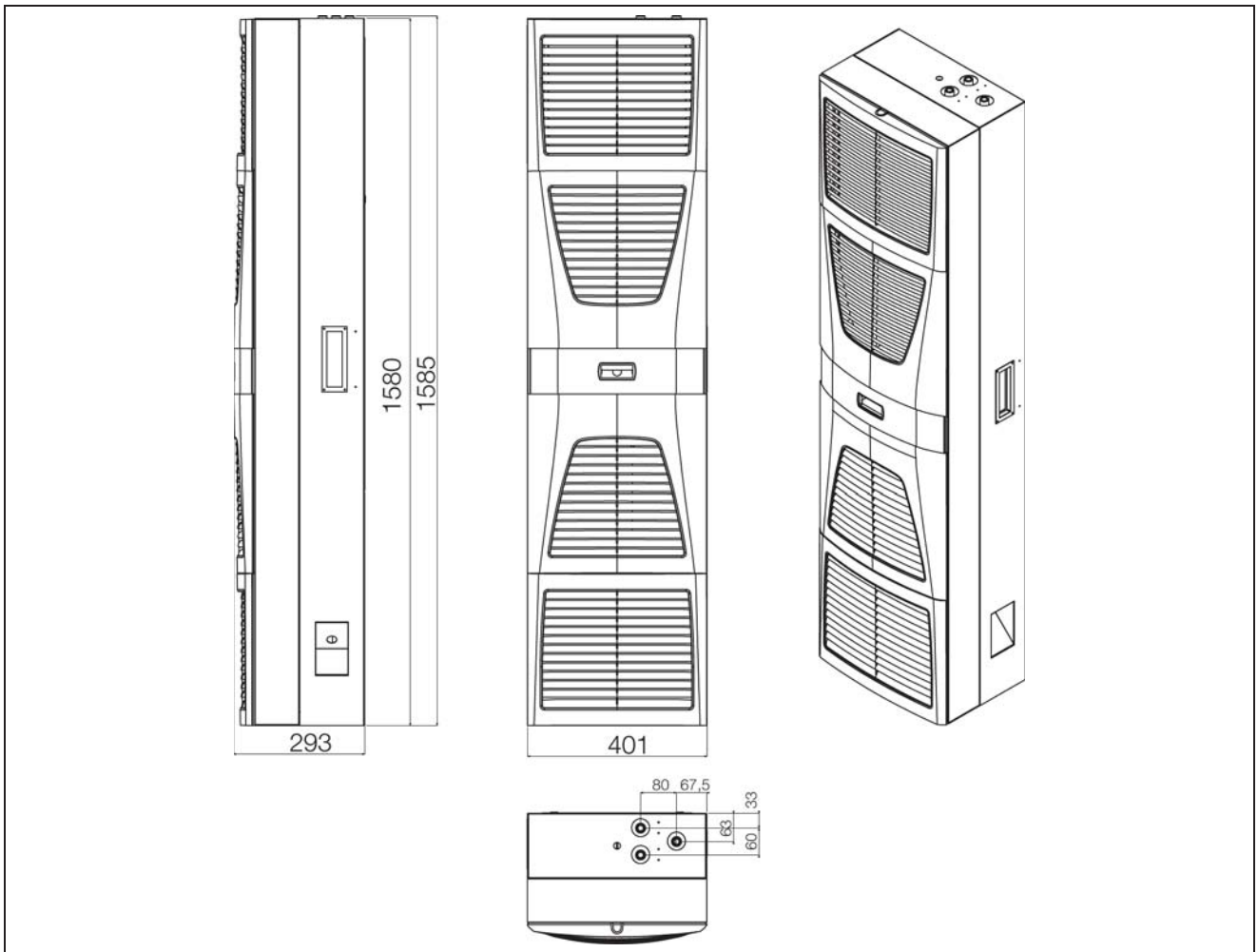

Fig. 23: Dimensions 3360.250

Mounting cut-out for external mounting/partial internal mounting/full internal mounting

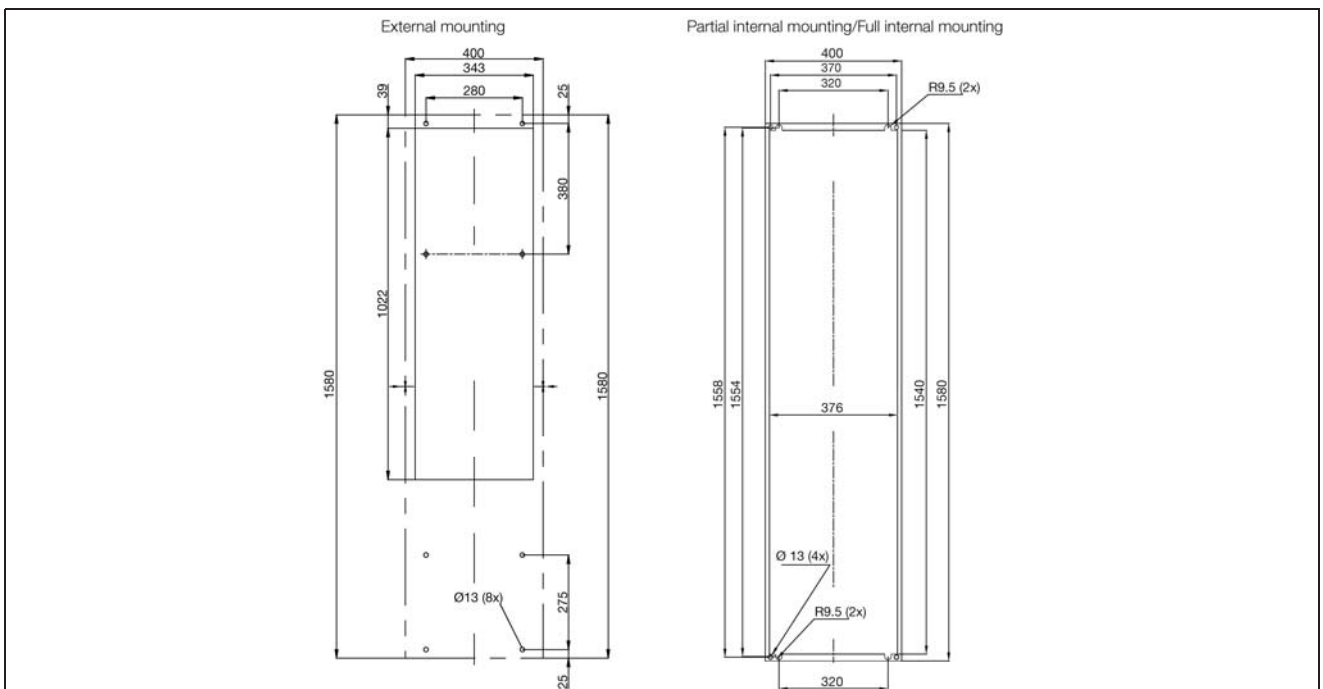

Fig. 24: Mounting cut-out for external mounting/partial internal mounting/full internal mounting

5 Assembly and connection

EN

5.1.6 Dimensions 3360.470

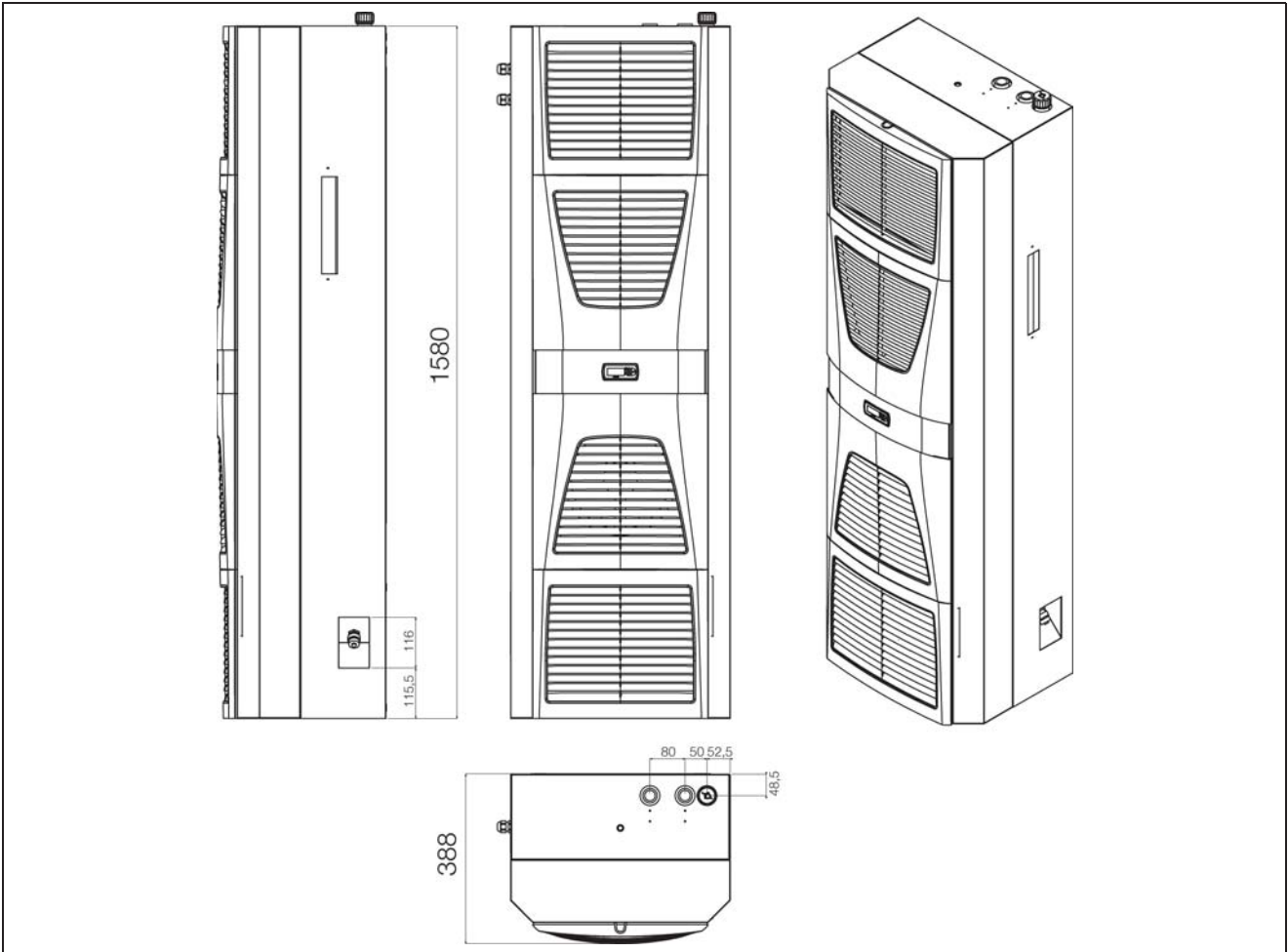

Fig. 25: Dimensions 3360.470

Mounting cut-out for external mounting/partial internal mounting/full internal mounting

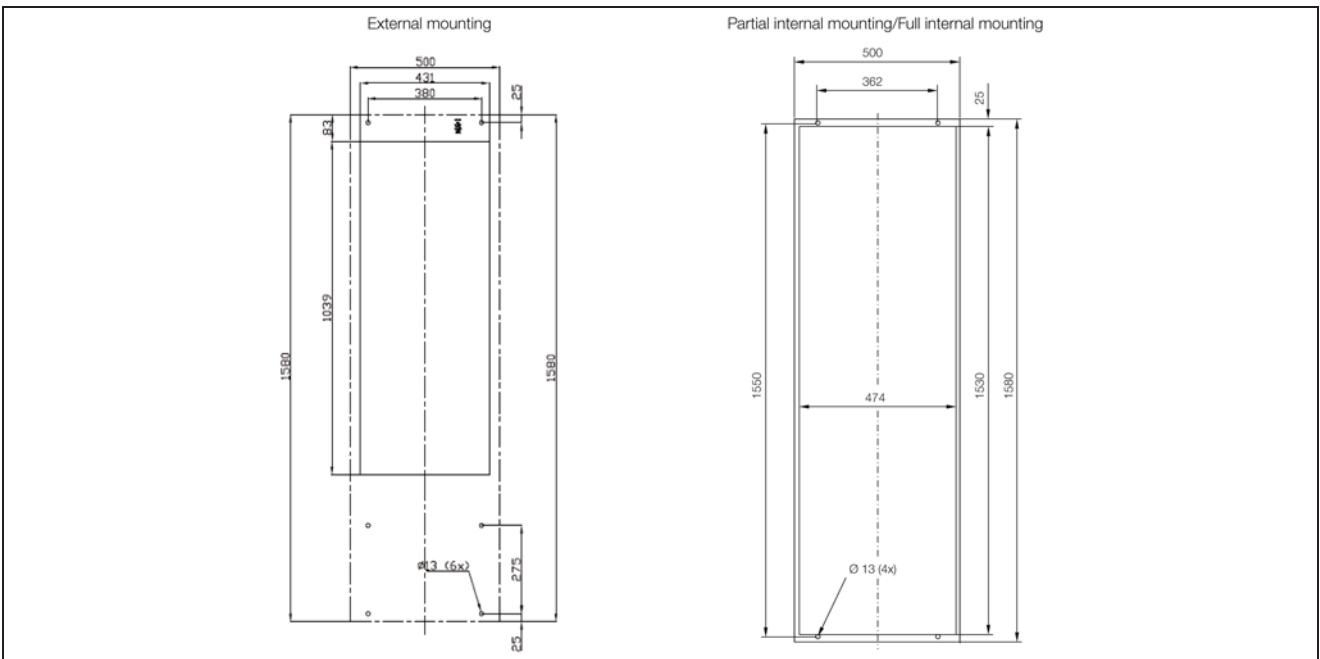

Fig. 26: Mounting cut-out for external mounting/partial internal mounting/full internal mounting

5.1.7 Assembling the chiller for wall mounting (3360.xxx)

The chillers for wall mounting (3360.xxx) may optionally be externally mounted (1), partially internally mounted (2) or fully internally mounted (3):

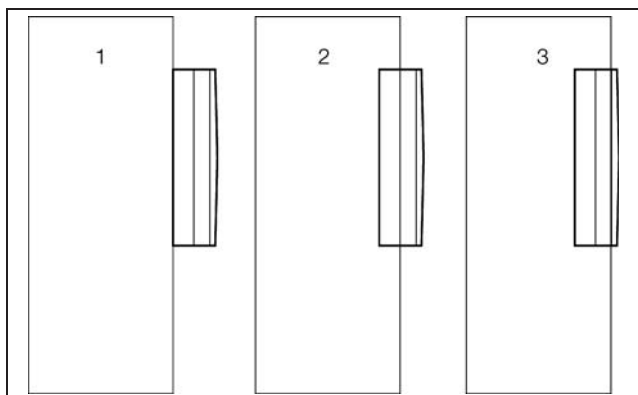

Fig. 27: Installation method

Key

- 1 External mounting
- 2 Partial internal mounting
- 3 Full internal mounting

Using the dimension drawings (see section 5.1 "Dimensions"), identify the valid lines and dimensions for your installation type on the drilling template.



Risk of injury!
Carefully deburr all drilled holes and cut-outs to prevent injuries caused by sharp edges.

- Mark, drill and deburr the holes.
- Make the cut-outs including the line width as per the drawing. Deburr the cut-outs.

External mounting of the chiller

- Cut the supplied sealing tape to the correct length and stick it carefully along the back of the unit so that no gaps are left at the joints.

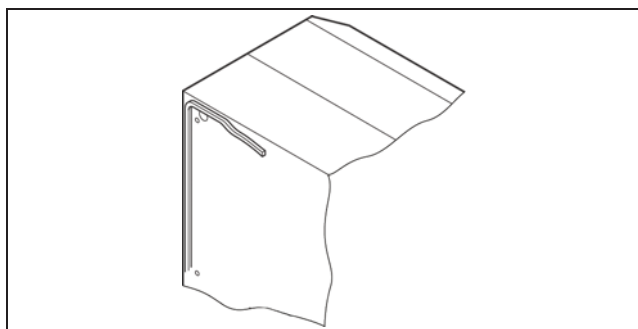

Fig. 28: Applying the self-adhesive tape

- Screw the supplied grub screws into the blind nuts on the rear of the unit.

- Secure the chiller using the supplied washers and nuts.

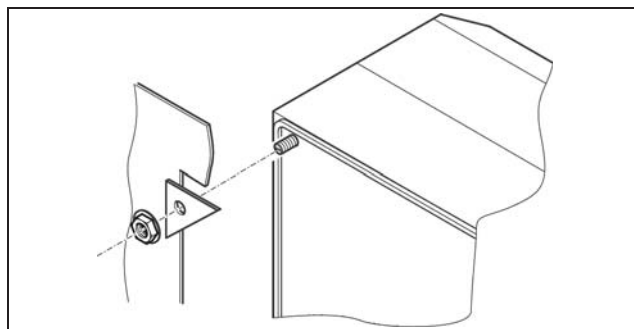

Fig. 29: Securing the chiller

Partial internal mounting of the chiller

- Carefully remove the louvred grille and, where applicable, the infill panel, from the enclosure by pulling forwards.
- Carefully disconnect the connector from the rear of the display and gently push it inwards through the cable gland.

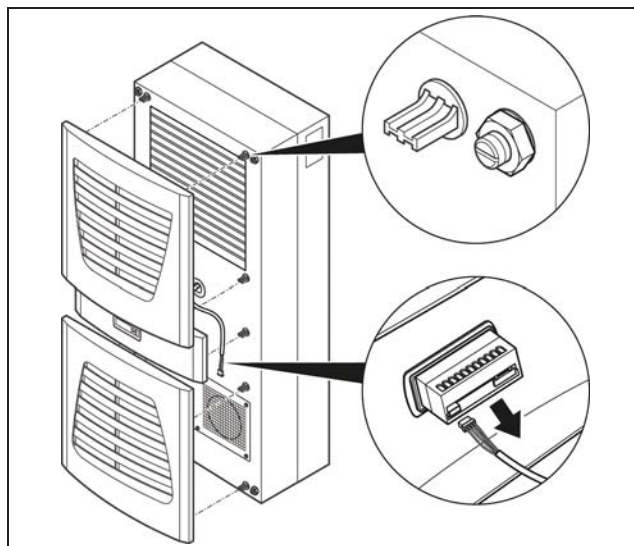

Fig. 30: Removing the louvred grille & disconnecting the display



Risk of damage!
Stability of the chiller is only guaranteed in its assembled state. Brace the rear enclosure half to prevent it from falling over before removing the front enclosure half.

- Loosen the four nuts on the front enclosure half and pull the enclosure forwards by approx. 5 cm.
- Loosen the flat-pin connectors of the PE conductor between the two enclosure halves.
- Disconnect the fan connection.
- Remove the front enclosure tray completely.

5 Assembly and connection

EN

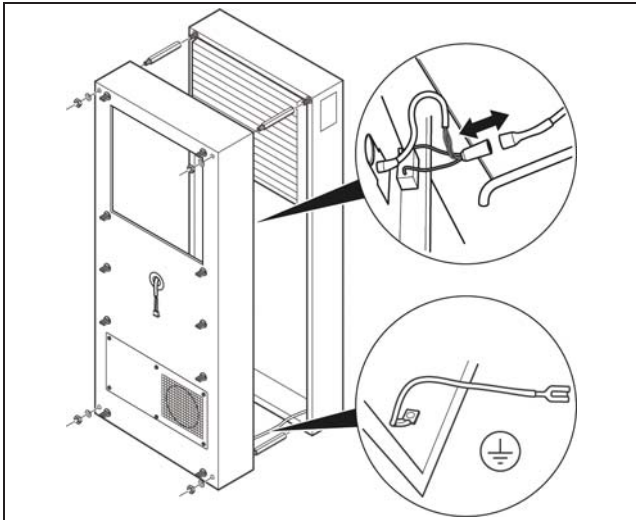

Fig. 31: Removing the cover

- Remove the four spacer bolts.
- Cut the supplied sealing tape to the correct length and stick it carefully along the inside of the rear enclosure half so that no gaps are left at the connection points.

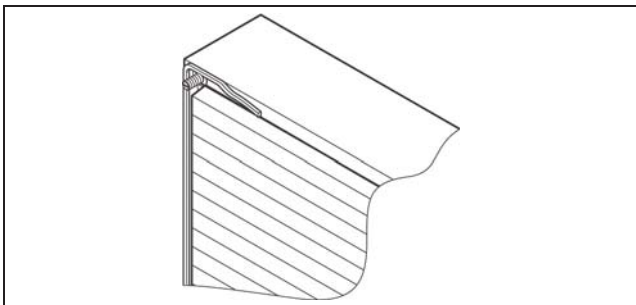

Fig. 32: Applying the self-adhesive tape

- Push the rear enclosure half into the mounting cut-out and secure it with the four spacer bolts.
- Push the display cable through the cable gland of the front enclosure half.

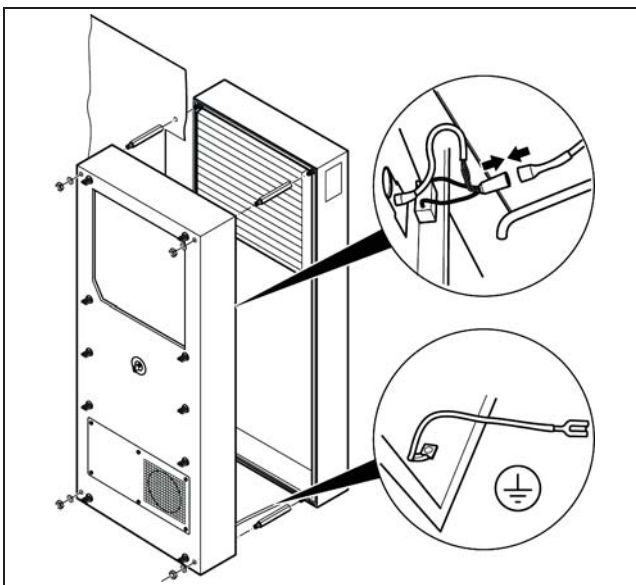

Fig. 33: Securing the chiller

- Connect the fan connector and PE conductor.

- Mount the front enclosure tray using the washers and nuts.

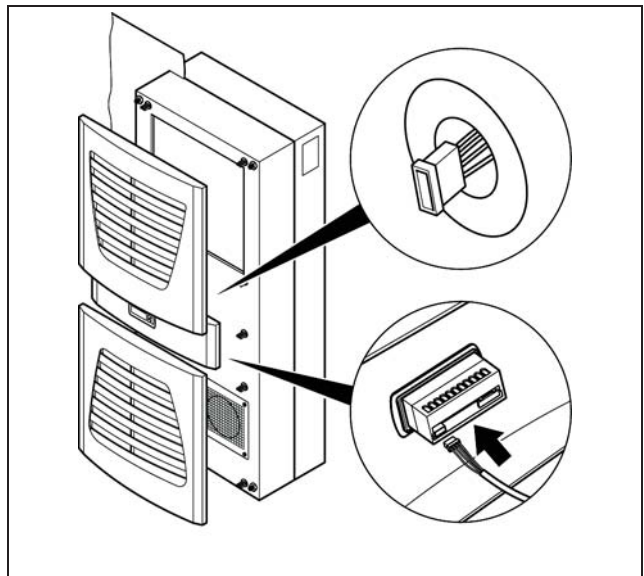

Fig. 34: Connecting the display connector

- Carefully connect the display connector.
- Push the louvred grille and, where applicable, the infill panel, onto the enclosure.

Full internal mounting of the chiller

- Carefully remove the louvred grille and the infill panel from the enclosure by pulling forwards.
- Carefully disconnect the connector from the rear of the display.

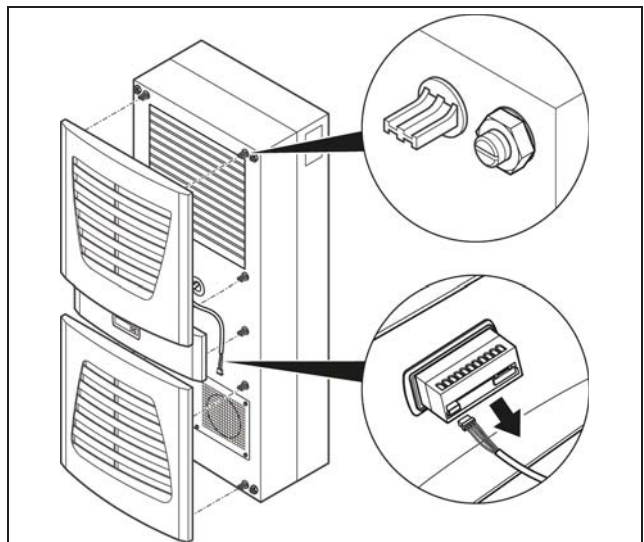

Fig. 35: Removing the louvred grille & disconnecting the display

- Cut the supplied sealing tape to the correct length and stick it carefully along the front enclosure half so that no gaps are left at the connection points.

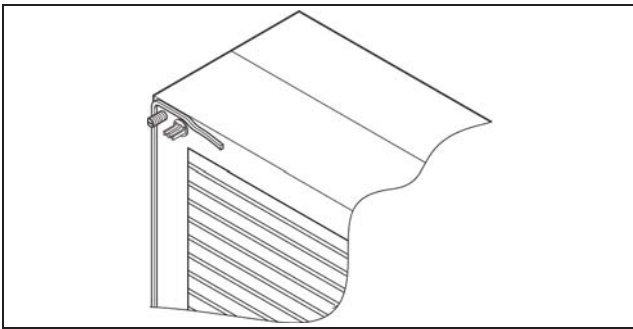

Fig. 36: Applying the self-adhesive tape

- Loosen the four nuts and washers from the front enclosure half.
- Push the chiller into the mounting cut-out from the inside of the enclosure, and secure it to the enclosure from the outside using the washers and nuts.

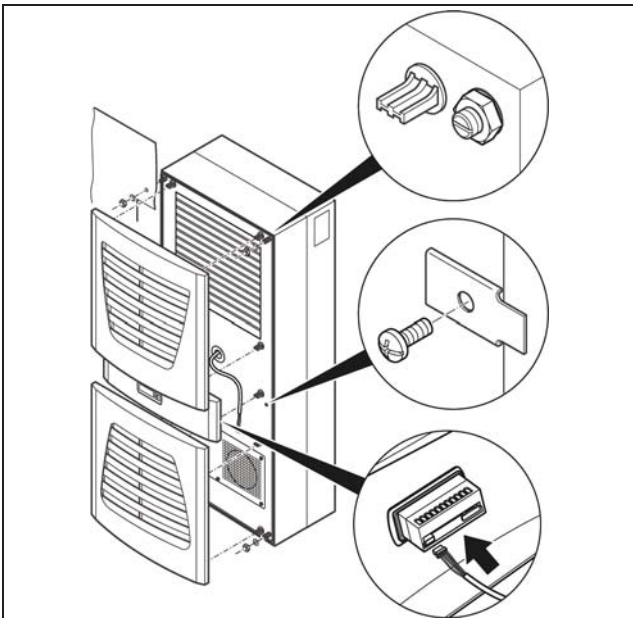

Fig. 37: Securing the chiller

- Where necessary, additionally secure the chiller using the supplied mounting plates.
- Carefully connect the display connector.
- Push the louvred grille and, where applicable, the infill panel, onto the enclosure.

5.2 Installation site requirements

- The chiller must be adequately protected from external weather conditions.
- If the ambient air contains a high concentration of dust or oily substances, the chiller should be fitted with a metal filter (see section 11 "Accessories").
- The supporting surface should be flat and sufficiently robust to hold the weight (see rating plate) during operation.
- The ambient temperature must not exceed +43°C nor fall below +10°C.
- In order to prevent performance losses caused by pressure drops in the pipework, the chiller should be sited as close as possible to the equipment.

- In order to make maintenance and repair work easier, the minimum distances shown under fig. 38 or fig. 39 should be adhered to.
- In order to avoid an "air short-circuit" (mixing of air intake and waste air) and ensure full cooling output, the minimum distances shown under fig. 38 or fig. 39 should be adhered to.

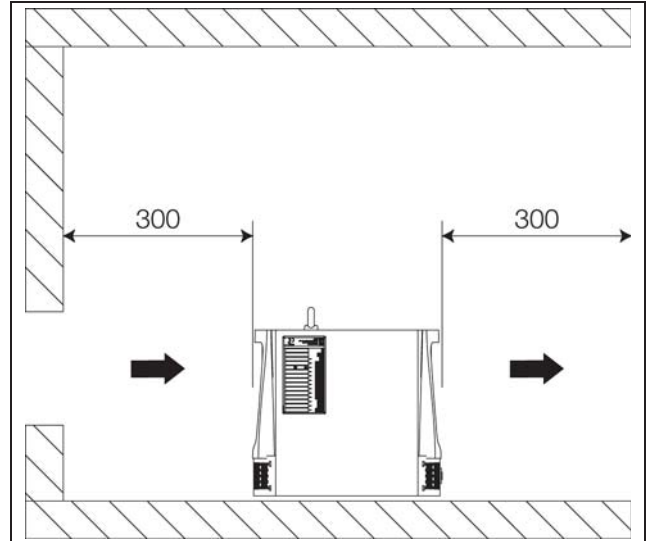

Fig. 38: Minimum distances

TopTherm chiller for wall-mounting

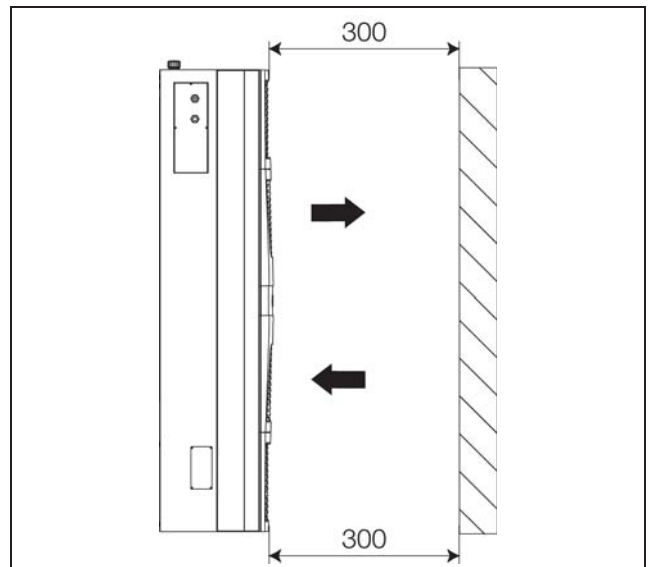

Fig. 39: Minimum distances



Note:

For unit types 3318.600, 3318.610, 3319.600, 3319.610, 3334.660 the airflow passes through the chiller from front to back. With unit types 3320.600 and 3334.600 the airflow passes through the chiller from back to front.

- Ensure the room is adequately ventilated by installing the chiller such that the warm exhaust air does not heat the room excessively.

5 Assembly and connection

EN

- In case of installation in a "small" room, it is imperative that you provide forced ventilation, as otherwise the heat dissipated will build up.



Caution!

The connection of an air intake / waste air duct is inadmissible. These devices are equipped with axial fans and are incapable of developing the requisite pressure resistance.

- To prevent performance losses, do not install the chiller near any form of heating.

Outdoor siting

Chillers must be installed such that they cannot become damaged by internal traffic and transport operations.

5.3 Installing the chiller

- Install the chiller on an even, firm surface. The maximum permissible deviation from the vertical is 2°.
- Avoid the production of noise due to vibration (vibration dampers, sheets of foam rubber).

5.4 Making the hydraulic connection



Caution!

Risk of damage to the cooling medium pump due to soiling in the cooling medium circuit! Flush the cooling medium circuit prior to connecting the chiller.

The cooling medium outlet (fig. 2, item 6 or fig. 3 to fig. 9, item 9) on the chiller must be connected to the cooling medium inlet on the equipment to be cooled. At the same time, the cooling medium inlet (fig. 2, item 8 or fig. 3 to fig. 9, item 10) on the chiller must be connected to the cooling medium outlet on the equipment to be cooled. Please observe the following:

- To avoid condensation, always connect the equipment using insulated pipelines and/or hoses.
- The nominal width of the piping must correspond at least to the nominal width of the media connections on the chiller.
- The pipework must be approved for the maximum pressure expected (see section 12.4 "Technical specifications").



Note:

To drain the cooling medium tank on models 3318.610 and 3319.610 we suggest installing an external discharge appliance at the cooling medium output. If you don't have such a discharge appliance installed you have to loosen the piping (at the cooling medium output) to drain the medium tank.



Note:

The use of steel pipes or galvanised steel pipes is inadmissible.

For pressure-sealed chillers (3318.600 and 3319.600)

- Install a pressure manometer, 0 to 6 bar, in the cooling medium circuit.

For types 3320.600, 3334.600 and 3334.660 only

Prior to commissioning, it is imperative that the cooling medium pump is filled with cooling medium and bled (see section 6 "Commissioning").

In the case of a water-cooled condenser (option), the operator must:

- Make the cooling water connections.



Caution!

Risk of damage for the chiller!

Insufficient pressure (on pressure-sealed chillers) and an excessively low flow rate will trigger the safety devices in the chiller. Pay attention to the minimum pressure required and the minimum flow rate required (see section 12 "Appendix").

Only for types 3318.610, 3319.610, 3320.600, 3334.600, 3334.660, 3360.100, 3360.250, 3360.470 that are open to the atmosphere

If the cooler on the equipment to be cooled is higher than the chiller, we recommend installing a non-return valve in the feed as well as a solenoid valve in the cooling medium circuit return to prevent the tank from overflowing.



Caution!

Risk of damage for the cooling medium pump due to dry running! If it is possible to shut off the circuit to the equipment to be cooled, you must install a bypass valve (can be ordered as an option) between the feed and return to protect the cooling medium pump.

5.5 Making electrical connection



Danger!

It is imperative that you follow the instructions given below.

- When carrying out the electrical installation, observe all applicable national and regional regulations as well as the regulations from the responsible utility company. Electrical installation must only be carried out by a qualified electrician who is responsible for compliance with the existing standards and regulations.

- The connected voltage and frequency must correspond to the values stated on the rating plate.
- The chiller must be connected to the mains via an all-pole isolating device.
- For single-phase units: Install the pre-fuse cited on the rating plate (miniature circuit-breaker "K" characteristic or slow fuse) to protect the cable and equipment from short-circuits.
- For 3-phase units: Set the pre-fuse (motor circuit-breaker) as per the specifications on the rating plate.
- The mains connection must ensure low-noise potential equalisation. Chillers must always be integrated into the building's equipotential bonding system.
- The conductor cross-sections of the power cable must be selected according to the rated current (see rating plate).
- The chiller does not have its own overvoltage protection. Measures must be taken by the operator at the supply end to ensure effective lightning and overvoltage protection. The mains voltage must not exceed a tolerance of +6%/-10% (see section 12 "Appendix").
- For 3-phase units: The connection must be made with the field rotating clockwise. The direction of rotation of the field can be measured at the connection terminals L1, L2 and L3. Connection with a clockwise rotating field ensures that all three-phase motors rotate in the correct direction.
- In case of an integrated transformer (optional): Ensure correct voltage connection on the primary side.



Note:

If the chiller has a black main switch (option), a respective emergency-off device must be installed in addition according to DIN EN 60204. If this is not provided by the customer, the EC declaration of conformity will not be valid.

If you want to evaluate the fault codes for fault signals from the chiller using the alarm relay, you must also connect an appropriate low voltage cable to terminals 3 – 8 (see circuit diagram for the relevant unit type in section 12 "Appendix").

If the chiller requires remote switching, terminals 1 and 2 can be used for this purpose (see circuit diagram for the relevant unit type in section 12 "Appendix") together with the appropriate programming (parameter 18) (see section 7.4 "Meaning of the control parameters").

5.5.1 Connecting the power supply

The chiller is prewired ready for connection in the factory and equipped with a twelve-wire connection cable (length 2.5 m) (except 3360.100, .250, .470).

- Make the electrical connection as per the electrical circuit diagram (see circuit diagram for the relevant unit type in section 12 "Appendix").

5.5.2 Connecting the alarm relay query device

You can also query fault messages with two floating contacts on the connection clamps of the chiller. The necessary wires are already present in the connection cable and are connected in the chiller.

- Connect the correspondingly labelled wires of the connection cable to the controller as shown in the electrical circuit diagram (see circuit diagram for the relevant unit type in section 12 "Appendix").

For details on the assignment of alarm relay contacts when an error code is displayed, see section 7.6 "Alarm relay function".

5.5.3 External activation

The chiller has been prepared for control via an external signal. To implement this, the customer must connect 24 V DC to contacts 1 and 2 (note polarity) (see circuit diagram in section 12 "Appendix") and set parameter 18 to the desired function (e.g. "1") (see section 7.4 "Meaning of the control parameters").

5.5.4 Connecting the chiller to the PLC

To evaluate individual fault messages, the chiller can be connected to a programmable logic controller (PLC). The connection is made with a 15-pole Sub-D socket.

- Use a suitable line to connect the PLC to the 15-pin Sub-D socket.

Types 3318.600, 3318.610 and 3319.600, 3319.610

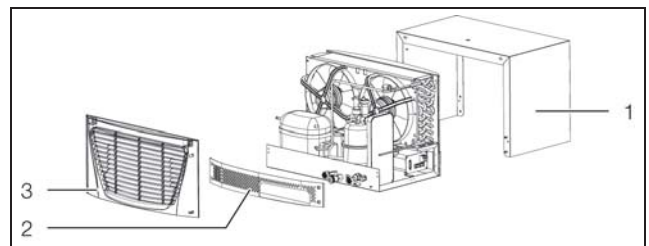

Fig. 40: Preparing the PLC connection (3318.600, 3318.610 and 3319.600, 3319.610)

- Remove the louvred grille (fig. 40, item 3) on the rear of the chiller.
- Remove the belt (fig. 40, item 2) and the housing (fig. 40, item 1).

5 Assembly and connection

EN

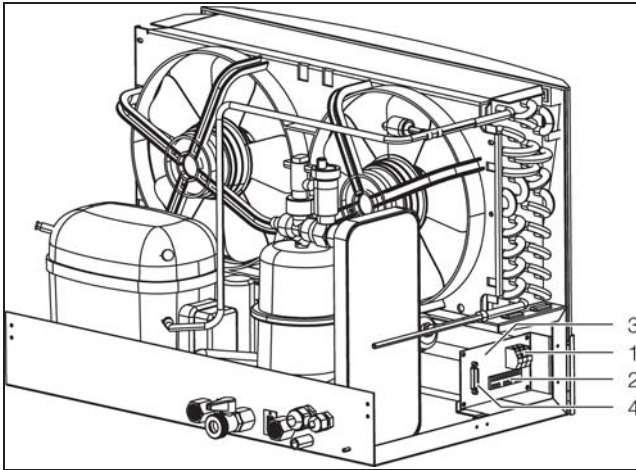

Fig. 41: PLC connection (3318.600, 3318.610 and 3319.600, 3319.610)

- Guide a suitable connection cable into the chiller via the additional cable gland provided (fig. 2, item 5).
- Connect the cable to the 15-pole Sub-D socket (fig. 41, item 4).

Types 3320.600 and 3334.600

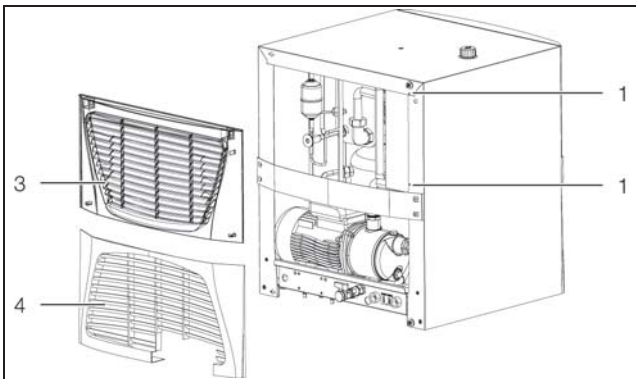

Fig. 42: Preparing the PLC connection (3320.600 and 3334.600)

- Remove the louvred grilles (fig. 42, items 3 and 4) on the rear of the chiller.
- Remove the filter mat, if applicable.
- Guide a suitable connection cable into the chiller via the additional cable gland provided (fig. 4, item 4).
- Connect the cable to the 15-pole Sub-D socket (fig. 43, item 5).

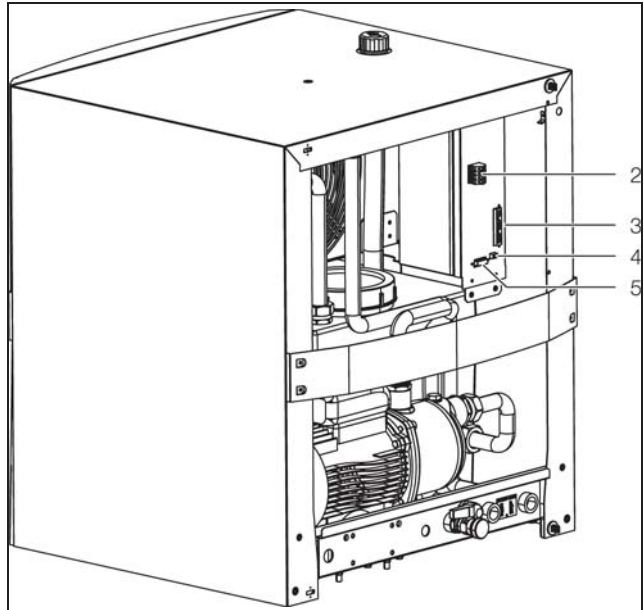

Fig. 43: PLC connection (3320.600 and 3334.600)

Type 3334.660

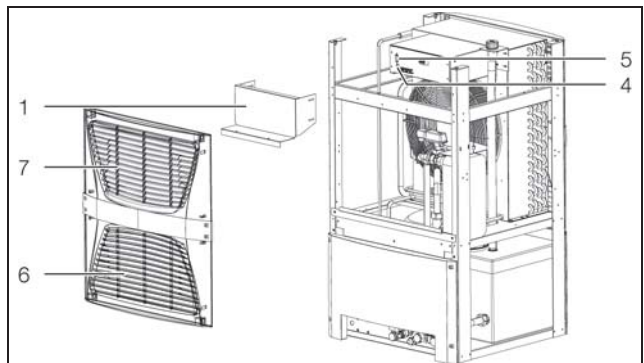

Fig. 44: PLC connection (3334.660)

- Remove the louvred grilles (fig. 44, items 6 and 7) on the rear of the chiller.
- Connect the cable to the 15-pole Sub-D socket (fig. 44, item 5).

Types 3360.100, 3360.250, 3360.470

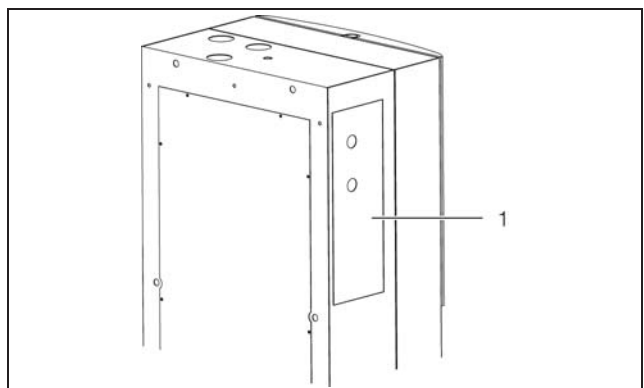

Fig. 45: PLC connection (3360.100, 3360.250, 3360.470)

- Open the service flap (fig. 45, item 1) on the left side of the chiller.
The PLC connection is marked with X2.

The following figure shows the assignment of the PLC contacts:

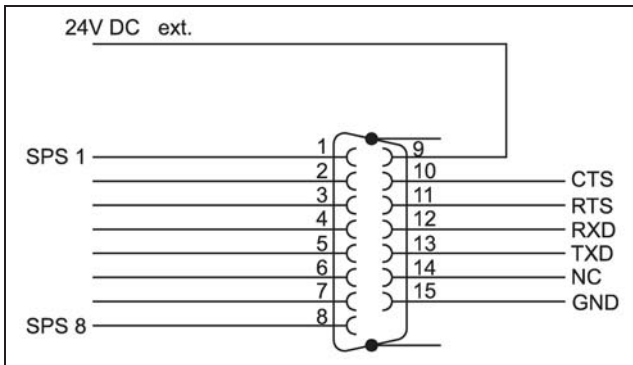

Fig. 46: Assignment of PLC contacts

For details on assigning PLC contacts when an error code is displayed, see section 7.7 "PLC outputs".

5.6 Room temperature sensor (option)

The chiller allows for room-temperature-based control. To this end, a room temperature sensor (cable length from chiller: 4 m) is required, which is available as an optional accessory.

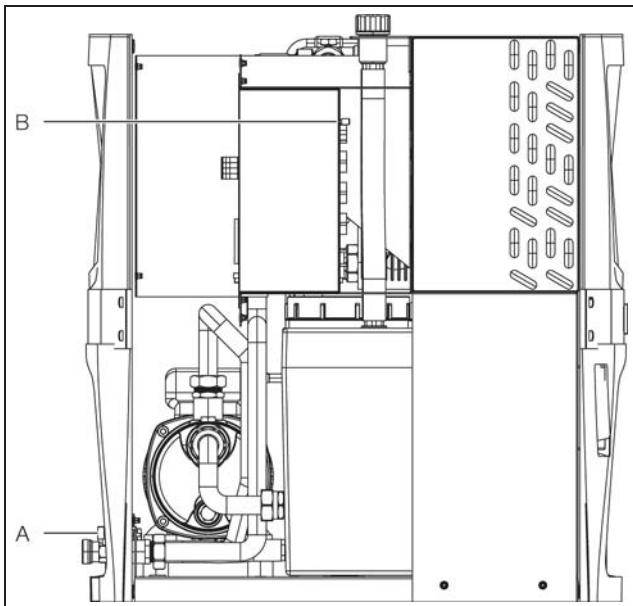

Fig. 47: Cable routing to room temperature sensor

- Guide the connection cable into the chiller via the additional cable gland provided (fig. 47, item A).
- Connect the connection cable on the electrical switch box to plug-type contact B5 (fig. 41, item 3, fig. 43, item 4 or fig. 44, item 4).
- **Types 3360.100, 3360.250, 3360.470 only:** Open the service flap (fig. 45, item 1).
- Connect the connection cable to plug-type contact B5.

After completing the connection work:

- Re-install the unit parts in the reverse order according to the device type.
- Activate the necessary parameters (see section 7 "Operation").

5.7 Installing the filter mats (accessories)

The chiller condenser is covered with a dirt-repelling, easy-to-clean RiNano coating. In many applications, therefore, the use of filter media is unnecessary, particularly with dry dusts.

For coarse dust and lint in the ambient air and/or air containing oil condensate, we recommend installing an additional metal filter mat (see section 11 "Accessories") in the chiller. The filter mats may be cleaned with suitable detergents and reused.

For the installation, proceed as follows:

Types 3318.600, 3318.610 and 3319.600, 3319.610 only

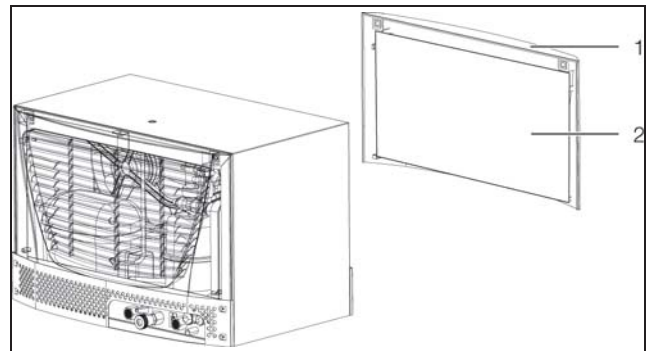

Fig. 48: Installing the filter mat (3318.600, 3318.610 and 3319.600, 3319.610)

- Pull the louvred grille (fig. 48, item 1) on the front of the chiller (air inlet) off of the housing.
- Insert the filter mat (fig. 48, item 2) (Model No. 3286.510) into the louvred grille and push it back onto the housing.

Types 3320.600 and 3334.600 only

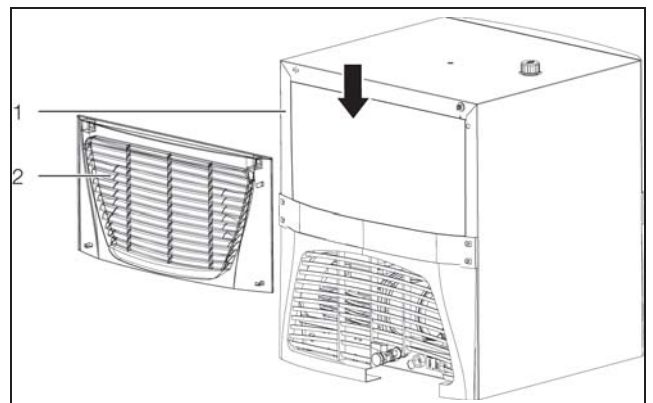

Fig. 49: Installing the filter mat (3320.600 and 3334.600)

- Remove the upper and lower louvred grille (fig. 49, item 1) on the rear of the chiller by carefully pulling it off the housing.
- Remove the belt. To do so, unscrew the screws.
- Insert the filter mat (fig. 49, item 2) (Model No. 3286.520) into the chiller from above.
- Reinstall the infill panel onto the chiller.
- Press both louvred grilles back onto the housing.

5 Assembly and connection

EN

Type 3334.660

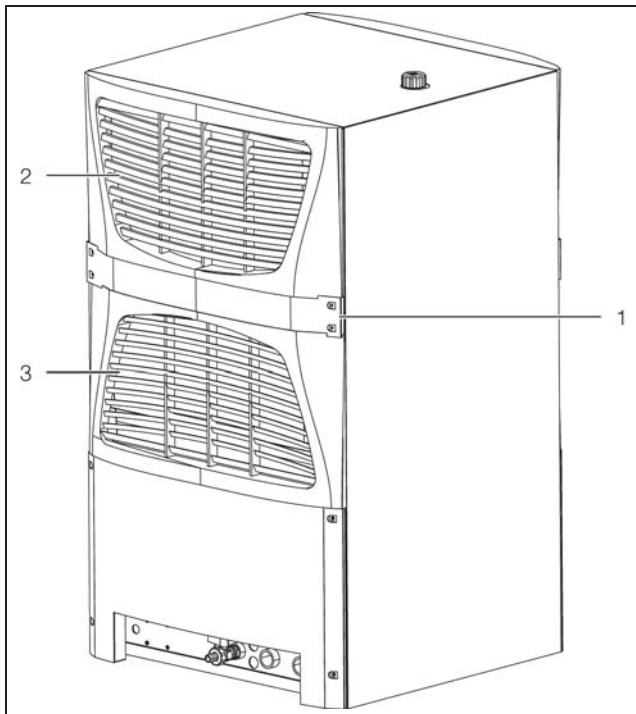

Fig. 50: Installing the filter mat (3334.660)

- Remove the infill panel (fig. 50, item 1). To do so, unscrew the screws.
- Pull the upper (fig. 50, item 2) and lower (fig. 50, item 3) louvred grille on the rear of the chiller (air inlet) off of the housing.
- Insert the filter mat (Model No. 2 x 3286.510) into the upper and lower louvred grille and push it back onto the housing.
- Reinstall the infill panel onto the chiller.

For types 3360.100, 3360.250 and 3360.470 only

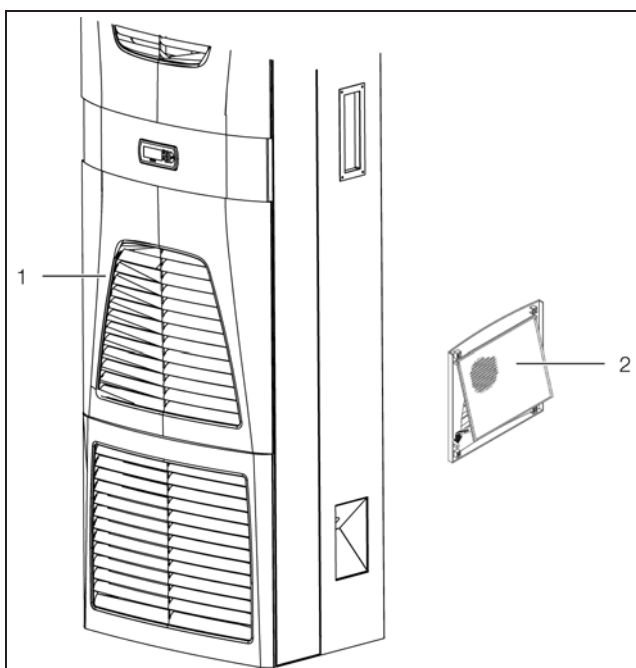

Fig. 51: Installing the filter mat (3360.100, 3360.250, 3360.470)

- Pull the louvred air inlet grille off the enclosure (fig. 51, item 1).
- Insert the filter mat (Model No. 3286.410) into the louvred grille (fig. 51, item 2) and push it back onto the housing.

5.8 Setting the filter mat monitor

Function of the filter mat monitor: Dirt on the filter mat is automatically detected by measuring the temperature difference at the air inlet and outlet of the condenser (sensors B3 and B4). As the level of filter mat soiling increases, the temperature difference will increase up to a definable switching threshold (see section 7.4 "Meaning of the control parameters", parameter 16).

6 Commissioning

The chiller does not have its own main switch to switch it on and off. It must be switched on and off by the higher-level controller.

6.1 Cooling medium

As standard, the chiller is not suitable for operation below the specified minimum temperature (see section 12 "Appendix").

Generally speaking, a water-glycol mixture with a maximum glycol proportion of between 20 and 34% by volume should be used as the cooling medium. We recommend our ready-mixed "Cooling medium for chillers" (see section 11 "Accessories"). Other water-glycol mixtures may be possible in individual cases, but only in consultation with the manufacturer. For further information, please refer to section 8 "Inspection and maintenance".

Model No.	Quantity [l]	Application
3301.950	10	Outdoor
3301.960	10	Indoor
3301.955	25	Outdoor
3301.965	25	Indoor

Tab. 6: Model numbers – Cooling medium for chillers



Note:

Only use distilled or de-ionised water in chillers specified for such use (see section 12 "Appendix").



Caution!

Other additives may damage the pipes and the seal on the cooling medium pump, and are therefore only admissible by arrangement with Rittal.

To prevent problems in the cooling medium circuit (including water-cooled chillers), it is imperative that the VGB Cooling Water Guidelines (VGB-R 455 P) are observed.

The correct glycol concentration proportions may be read and determined using a refractometer.

6.2 Filling the cooling medium

The composition of the cooling medium is described in section 8 "Inspection and maintenance".

For commissioning, proceed as follows:

- Ensure that any shut-off valves installed in the cooling medium circuit are open.

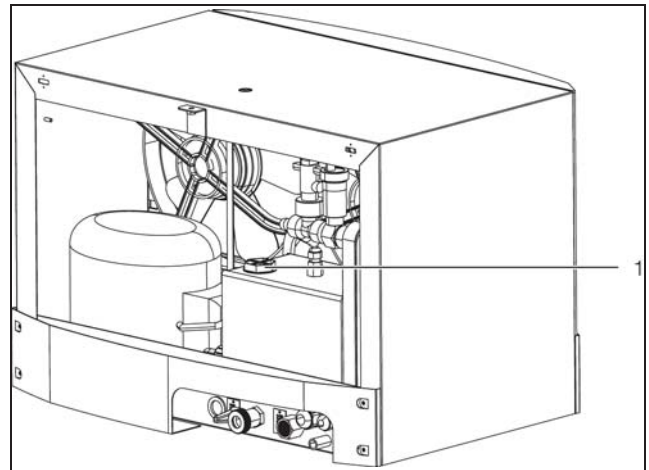

Fig. 52: Filling the cooling medium (3318.610 and 3319.610)

Types 3318.600 and 3319.600

- For pressure-sealed cooling medium circuits: Fill the circuit using a filler pump or water hose via the feed, return or drain cock (fig. 2), and build up a pre-pressure of 1.2 – 2 bar. This pressure can be read from the pressure manometer you have fitted.

Types 3318.610 and 3319.610

- Fill the chiller with cooling medium via the fill nozzle (fig. 52, item 1) in the tank.

Types 3320.600 and 3334.600

- Fill the chiller with cooling medium via the fill nozzle (fig. 4, item 4).
- Check the level on the level gauge (fig. 3, item 3).

Type 3334.660

- Fill the chiller with cooling medium via the fill nozzle (fig. 6, item 4). Check the level on the level gauge (fig. 5, item 3).

Types 3360.100, 3360.250, 3360.470

- Fill the chiller with cooling medium via the fill nozzle (fig. 7 to fig. 9, item 4).
- Check the level on the level gauge (fig. 7 to fig. 9, item 3).

6.3 Commissioning procedure

Types 3318.600, 3318.610, 3319.600, 3319.610, 3320.600, 3334.600, 3334.660

- Switch on the power supply to the chiller via the superordinate controller.
The indicators on the controller illuminate and indicate the actual feed temperature of the cooling medium.
- Check the direction of rotation of the motors (see direction of rotation arrows on the cooling medium pump and on the condenser fan).

6 Commissioning

EN



Note:

If the compressor and condenser fan do not start to operate, the temperature of the cooling medium added is lower than the setpoint temperature set.

- If necessary, lower the setpoint temperature momentarily (see section 7 "Operation").

Types 3318.600, 3318.610, 3319.600 and 3319.610

The cooling air is drawn in from the front and expelled to the rear.

Types 3320.600, 3334.600 and 3334.660

The cooling air is drawn in from the rear and expelled to the front.

If required, the condenser fan is activated by the temperature controller.

If the direction of rotation is incorrect, you must change over the connections for phases L1 and L2 on the chiller's terminal strip for the power supply.

6.4 Bleeding the cooling medium pump

- Bleed the pipes and top-up the cooling medium.

Types 3318.600, 3318.610, 3319.600, 3319.610, 3360.100, 3360.250 and 3360.470 only

The cooling medium pump fills by itself and does not need to be bled.

Types 3320.600 and 3334.600 only

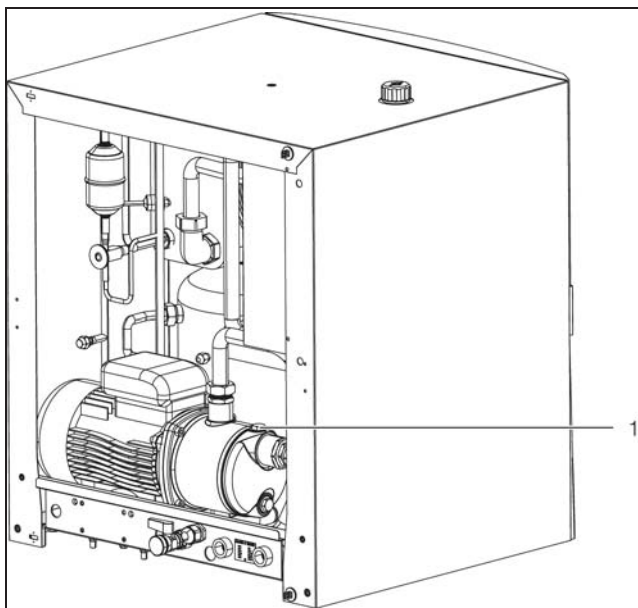

Fig. 53: Bleeding the cooling medium pump (3320.600 and 3334.600 only)

Type 3334.660 only

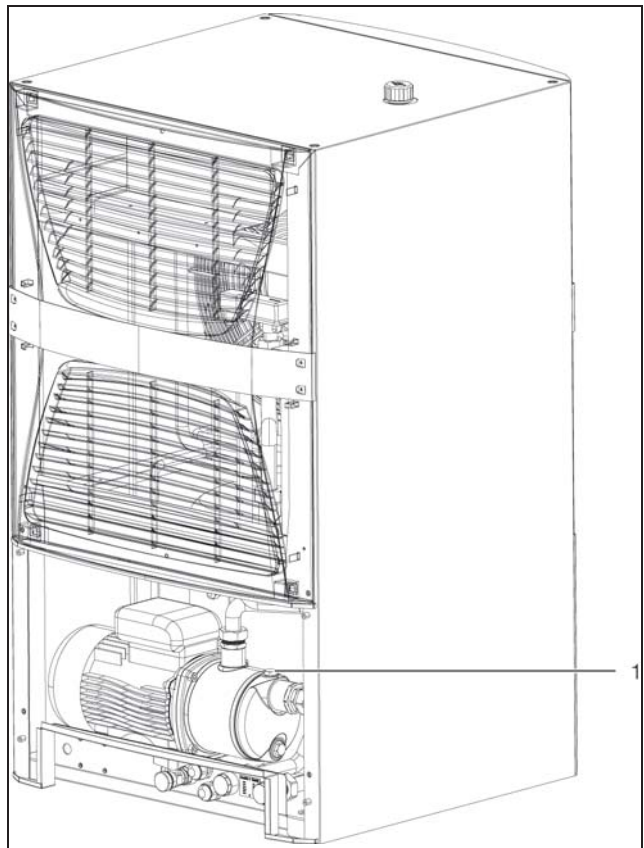

Fig. 54: Bleeding the cooling medium pump (3334.660 only)

- Bleed the cooling medium pump (with the system at a standstill) by loosening the bleed screw a little (fig. 53 or fig. 54, item 1).
- As soon as cooling medium escapes, re-tighten the screw.



Note:

With a water-cooled condenser (option), you must activate the external condenser circuit for the condenser (optionally by the operator).

- Check the connection lines and pipe connections for leaks during commissioning.

7 Operation

The chiller is switched on and off by the higher-level control. It operates automatically, i.e. the cooling medium is pumped continuously and heat extracted from it during this process.

A controller provides automatic control based on the hysteresis set. The controller has a display for the indication of temperature values and buttons for setting operating parameters.

7.1 Control components

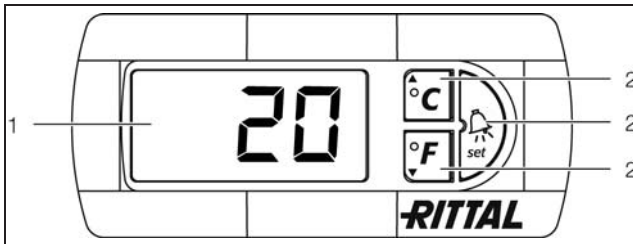

Fig. 55: Control components

Key

- 1 7-segment display
- 2 Control keys

The chillers have a 3-digit 7-segment display to indicate operating states and control keys to set operating parameters. After the power supply is switched on, the display "E0" appears initially for approx. 20 seconds to indicate that the unit is operational (boot phase controller). After the boot phase, the chiller will start to work. During operation, the inlet temperature (to the equipment) of the cooling medium circuit is displayed via the indicators, alternating with any error messages that are present in the form of error codes (see section 7.5 "Meaning of the error codes"). Two LEDs °C and °F are used as indicators for the temperature unit °C (Celsius) or °F (Fahrenheit). You can run the following activities via indicators and control keys:

- Reading temperature values
- Reading from error memory
- Acknowledging error messages
- Resetting the pump
- Reading and setting parameters for the controller

The measurement range for temperature measurements is:

- Celsius: -40°C to 70°C
- Fahrenheit: -40°F to 158°F

Temperatures are shown with a resolution of 0.1° in the following ranges:

- Celsius: -9.9°C to 70.0°C
- Fahrenheit: -9.9°F to 99.9°F

7.2 Key functions

You can use the control keys to change control parameters within the assigned ranges (min. to max. value). Tab. 7 in section 7.4 "Meaning of the control parameters" shows the parameters that may be set. The func-

tion of the control keys changes depending on which control level you are on.

7.2.1 Key functions during operation

The keys have the following functions during operation:



Display of software version: Press and hold.
Delete error memory when error memory is activated: Press and hold for 10 seconds.



Display of temperature values sensors 1 to 5 one after the other: Press repeatedly.
Sensor 1: Cooling medium temperature (displayed continuously or after 30 seconds menu timeout)
Sensor 2: Icing of evaporator unit
Sensor 3: Condenser, external (filter mat)
Sensor 4: Condenser, internal (filter mat)
Sensor 5: Room temperature (if combined controller active, see section 7.3 "Fixed value control or combined control")



Manual alarm reset
Parameter adjustment is interrupted if no key is pressed for approx. 30 seconds (or 10 seconds if an alarm is outstanding). If this is not done, the value will not be saved! The display shows the preset values again.



Jump to the parameterisation level, see section 7.2.2 "Key functions during parameter adjustment": Press both keys and hold for about 5 seconds.



To exit the parameterisation level, press both keys again and hold for about 5 seconds.

7.2.2 Key functions during parameter adjustment

Parameter adjustment is interrupted if you do not press any key for about 30 seconds. When this happens, any value in the process of being changed will not be saved! The indicators will then show normal operating values again (actual temperature of the cooling medium or the error code).



In selection mode: Parameter number is incremented from P01 to P20.
In editing mode: Parameter value is increased.



In selection mode: Parameter number is decremented from P01 to P20.
In editing mode: Parameter value is decreased.

7 Operation



EN



In parameter selection: Switch to editing mode.
 In editing mode: Accept parameter and increment to the next parameter.
 After the last parameter (display 'End'): Exit parameter adjustment.

Example: Change setpoint temperature

You can change the default medium setpoint temperature ($T_w = 20^\circ\text{C}$). To do this, proceed as follows.

- Press keys °F and °C and hold for about 5 seconds. You are on the parameterisation level.
- Press key °C until parameter P17 is displayed.
- Press key  to switch into editing mode.
- You can use the keys °F or °C to change the setpoint as required.
- Press key  to confirm entry and switch to next parameter.
- Press keys °F and °C and hold for about 5 seconds to exit the parameter level.

7.3 Fixed value control or combined control

Chillers allow for both fixed value control and combined room temperature-based control.

The chillers are set to "Fixed value control" in the factory. If you have connected an external room temperature sensor (see section 5.6 "Room temperature sensor (option)"), available as an option, you can set control mode "Combined control" on the controller with parameter 13 (see section 7.4 "Meaning of the control parameters"). In combined control, additional control parameters must be set or taken into consideration (see section 7.4 "Meaning of the control parameters").

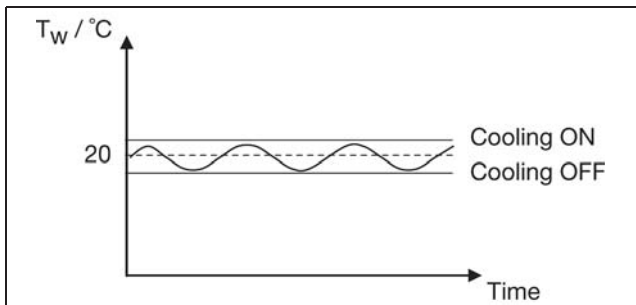

Fig. 56: Fixed value control

Key

Setpoint T_w : 20°C
 Hysteresis: 2 K

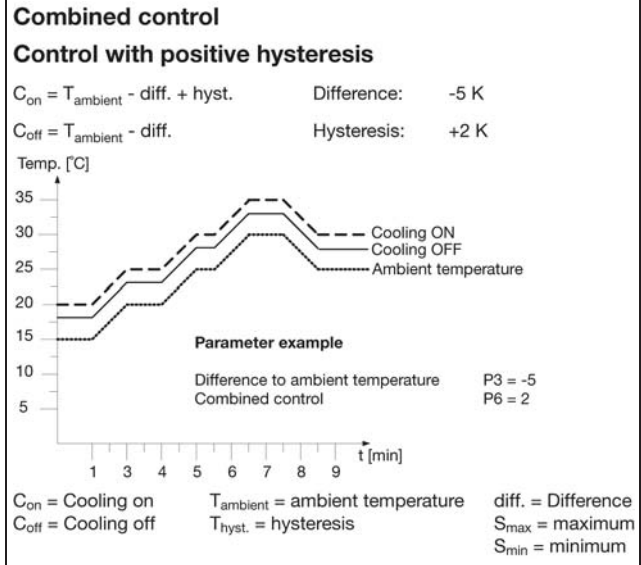

Fig. 57: Combined control



7.4 Meaning of the control parameters

No.	Parameter	Min. value	Max. value	Factory setting	Explanation
Fixed value control					
1	Setpoint temperature with fixed value control	10.0°C	30.0°C	20.0°C	If fixed value control is set for parameter 13, the setpoint temperature can be selected here.
2	Switching hysteresis with fixed value control	2 K	5 K	2 K	If fixed value control is set for parameter 13, the switching hysteresis can be determined here.
Combined control					
3	Difference from room temperature	-10.0°C	10.0°C	5.0°C	If combined control is set for parameter 13, the setpoint temperature can be set with this parameter as the difference compared to room temperature. Negative values result in a setpoint above the ambient temperature.
4	Minimum setpoint	7.0°C	P5	10°C	If combined control is set for parameter 13, the setpoint can be limited below with this value.
5	Maximum setpoint	P4	35.0°C	28.0°C	If combined control is set for parameter 13, the setpoint can be limited above with this value.
6	Switching hysteresis with combined control	2 K	5 K	2 K	If combined control is set for parameter 13, the switching hysteresis can be determined here.
7	Tolerance for error message "F.01"	3.0°C	15°C	5.0°C	If the cooling medium temperature exceeds the switching on temperature of the compressor by the value set here, error message F.01 and an alarm are generated.
8	Heater control (medium)	0.5°C	3.0°C (+ OFF)	OFF	Optional: Optional if a tank heater is installed. The heater will cut in if the tank temperature drops below the value set here. If OFF is set, the heater will never cut in.
9	Real-time clock	–	–	–	One after another, the hour (0...24), minute (0...59), year (00...99), month (1...12), day (1...31), summer-time (OFF, EU; USA, S1...S12, E1...E12) are displayed.
10	Switching times – compressor	OFF	ON	OFF	Select the day of the week (1Mo...7Su, ESC), start time (hh, mm), end time (hh, mm)
11	Switching times – heater	OFF	ON	OFF	Only if P8 not OFF. Select the day of the week (1Mo...7Su, ESC), start time (hh, mm), end time (hh, mm)
12	Key number 1 (password protection)	1	999	123	To call up parameters P13...P19, key number 123 must be set.
13	Control mode	Ct	Ft	Ft	Ct: Combined control Ft: Fixed value control



Tab. 7: Meaning of the control parameters

7 Operation

EN

No.	Parameter	Min. value	Max. value	Factory setting	Explanation																		
14	Heater function anti-freeze (optional)	OFF	ON	OFF	Optional if a heater is installed. ON: +2°C; OFF: +5°C																		
15	Hot gas bypass (optional)	OFF	ON	OFF	<p>OFF: Hot gas bypass control inactive ON: Hot gas bypass control active</p> <p>When P15 is activated, the switching hysteresis (P2 and P6) is deactivated. The PID controller will automatically aim for optimum switching hysteresis. This is dependent on the PID setting. The P, I and D values, cycle time C and switching hysteresis T of the controller are each set in turn. Parameter T can be used to set a hysteresis for switching off the compressor. This setting defines how far the medium temperature may drop below the preset setpoint temperature (in case of a low demand for cooling power).</p> <p>PID controller settings:</p> <table border="1"> <thead> <tr> <th>PID controller</th> <th>Min. – max.</th> <th>Default</th> </tr> </thead> <tbody> <tr> <td>P</td> <td>0.1 - 99.9</td> <td>1</td> </tr> <tr> <td>I</td> <td>1 - 999 sec</td> <td>300</td> </tr> <tr> <td>D</td> <td>1 - 999 sec</td> <td>50</td> </tr> <tr> <td>C</td> <td>4 - 100 sec</td> <td>10</td> </tr> <tr> <td>T</td> <td>1 - 5</td> <td>5</td> </tr> </tbody> </table> <p>Key: P: Proportional band I: Integral time (0=inactive) D: Derivative time (0=inactive) C: Cycle time T: Hysteresis (temperature difference in the low-load range)</p> <p>Note: Analyse to optimise the controlled system and contact customer service.</p>	PID controller	Min. – max.	Default	P	0.1 - 99.9	1	I	1 - 999 sec	300	D	1 - 999 sec	50	C	4 - 100 sec	10	T	1 - 5	5
PID controller	Min. – max.	Default																					
P	0.1 - 99.9	1																					
I	1 - 999 sec	300																					
D	1 - 999 sec	50																					
C	4 - 100 sec	10																					
T	1 - 5	5																					
16	Setpoint for filter mat monitoring	4.0 K	70.0 K (+ OFF)	OFF	<p>Make the setpoint settings as follows (setting range 4.0...70.0°K, switching difference 2.0 K, fixed setting): Activate the chiller with a clean filter mat inserted.</p> <p>Using the keys  and  set the value approx. 10.0°K above the difference between temperature probes B3 and B4.</p>																		
17	Changeover °C/°F	°C	°F	°C	<p>°C: Show temperatures in Celsius °F: Show temperatures in Fahrenheit</p>																		

Tab. 7: Meaning of the control parameters

No.	Parameter	Min. value	Max. value	Factory setting	Explanation
18	Evaluation of the external enable signal	1	7 (+ OFF)	OFF	<p>OFF: Normal operation</p> <p>1: Standby with signal absent (pump and compressor are disabled), display shows Stb.</p> <p>2: Cooling off with signal absent (pump is enabled)</p> <p>3: Control via external controller</p> <p>4: If signal is present at ext. input, clock control is deactivated. If signal is not present, clock control is active</p> <p>5: Standby with signal absent. If the system is on standby, the alarm relay 1 (contact 4-5) opens.</p> <p>6: If signal is present at ext. input, clock control is deactivated. If signal is not present, alarm relay 1 opens and alarm relay 2 closes. Clock control is active.</p> <p>7: If signal is present at ext. input, clock control is deactivated. If signal is not present, alarm relay 1 and alarm relay 2 open. Clock control is active.</p>
19	Acknowledgement of error messages	OFF	ON	OFF	<p>If this function is activated (ON), the error messages also appear on the display with auto-reset until acknowledged with the key</p> 
20	Factory setting	1	999	555	<p>To accept the factory setting, code number 555 must be entered.</p> <p>This setting level is reached by pressing the  key for approx. 10 seconds after parameter 19 (the word "End" is displayed).</p>

Tab. 7: Meaning of the control parameters

7.5 Meaning of the error codes

If errors occur during operation, they will appear cyclically as error codes with the cooling medium temperature:

The format of this display is as follows:

e.g. F.01 alternating with t1

Error messages that occur are saved in the controller's error memory. You can delete the error codes with control parameter 19 (see section 7.4 "Meaning of the control parameters").

The meaning of the individual error codes are as follows:

7 Operation

EN

Error	Meaning	Alarm reset	Alarm relay function	Assigned PLC output	Cause	Remedy
F.01	Maximum cooling medium temperature exceeded	Auto	1	1	The cooling medium temperature has exceeded the activation temperature of the compressor by the value set in parameter 7.	Wait until the error message disappears or occurs again after being acknowledged or other error messages are displayed. Remedy, see that section.
F.02	Winding protection on the compressor has tripped.	Man	8	2	Compressor overheated	Leave compressor to cool down. If the compressor has not re-started after approx. 3 hours, or shuts down again, contact service.
F.03	Icing in the plate heat exchanger	Auto	4	3	Insufficient cooling medium flow through the evaporator (plate heat exchanger)	Check whether a valve is shut in the cooling medium circuit. Check whether the cooling medium pump is running (listen). If faulty, contact service.
					Lack of refrigerant	If the cooling medium pump is not faulty, there is not enough refrigerant. Contact service.
F.04	Pressure switch in the refrigerant circuit has tripped due to excessive pressure.	Auto + Man > 3	5	4	Filter mat (option) soiled	Check whether filter mat is soiled. If applicable, replace or clean.
					Condenser soiled	Check whether the condenser is soiled and clean as necessary.
					Ambient temperature too high	Lower the ambient temperature. Ventilate room.
					Condenser fan faulty. Error as a consequence of F.05	Check whether the condenser fan is running. If necessary, wait a few minutes.
					Pressure switch has tripped.	Switches on again automatically (autoreset).
					In case of a water-cooled condenser (option), no water flow or an excessively low water flow through the condenser. Possibly external medium temperature.	Check external medium circuit and make water connection if necessary. Check external medium temperature. Contact service.
F.05	Winding protection for condenser fan has tripped.	Auto	8	5	Overheating	Contact service.

Tab. 8: Error codes

Error	Meaning	Alarm reset	Alarm relay function	Assigned PLC output	Cause	Remedy
F.06	Winding protection for cooling medium pump has tripped.	Auto + Man > 3	5	6	Overheating	Contact service.
F.07	Filter mat monitoring (optional, if activated) has tripped.	Reset: 0-3=Auto 4-7=Man	2	7	Filter mat (option) soiled Condenser soiled	Check whether filter mat is soiled. If applicable, replace or clean. Check whether the condenser is soiled and clean as necessary.
F.08	Low medium temperature if a tank heater (option) is installed.	Man	5	8	The medium temperature has dropped (cold environment!).	Check optional heater.
F.09	Incorrect rotary field or phase missing	Auto	5	8	Power supply incorrectly connected	Check and correct power supply.
F.10	Cooling capacity monitoring	Man	8	1	Cooling medium temperature too high. Consequently no cooling capacity. Lack of refrigerant	Switch off the chiller and wait until the temperature of the cooling medium has reached normal level. Contact service.
F.11	Flow switch in the cooling medium circuit has tripped.	Auto	5	6	Insufficient cooling medium flow through the evaporator (plate heat exchanger)	Check whether a valve is shut in the cooling medium circuit. Check whether the cooling medium pump is running (listen). If faulty, contact service.
					Cooling medium pump faulty	Replace pump and contact service as necessary.
					Plate heat exchanger iced up	Contact service.
					No or not enough cooling medium in the tank	Check cooling medium level and top up as necessary.
F.14	Mains voltage too high	Auto	5	7	Fluctuations in mains voltage	If temporary, no remedy is required. If error message persists, check the power supply.
F.15	Level switch (option) has tripped.	Man	5	2	Cooling medium level too low	Top up with cooling medium.
F.16	Condenser sensor (inlet/outlet) the wrong way round	Man	5	8	Condenser sensor the wrong way round	Check the arrangement of sensors B3 and B4. See section 12.1 "P+ID diagram".

Tab. 8: Error codes

7 Operation

EN

Error	Meaning	Alarm reset	Alarm relay function	Assigned PLC output	Cause	Remedy
F.81	Temperature sensor broken/short circuit in temperature sensor B1	Auto	5	8	Temperature sensor faulty	Replace temperature sensor.
F.82	Temperature sensor broken/short circuit in temperature sensor B2	Auto	5	8	Temperature sensor faulty	Replace temperature sensor.
F.83	Temperature sensor broken/short circuit in temperature sensor B3	Auto	5	8	Temperature sensor faulty	Replace temperature sensor.
F.84	Temperature sensor broken/short circuit in temperature sensor B4	Auto	5	8	Temperature sensor faulty	Replace temperature sensor.
F.85	Temperature sensor broken/short circuit in temperature sensor B5	Auto	5	8	Temperature sensor faulty	Replace temperature sensor.
CN	Lack of communication between the controller and the display	Man	–	–	Data cable faulty, no contact	Check connection, replace the data cable if necessary.
Operating status						
5E6	Standby				Chiller is in standby mode. For more information, see tab. 7 in section 7.4 "Meaning of the control parameters", parameter 18.	

Tab. 8: Error codes

7.6 Alarm relay function

The error codes are each assigned to an alarm relay function.

Function	Meaning
0	Both alarm relays remain closed when a malfunction occurs
1	Alarm relay 1 drops out when a malfunction occurs
2	Alarm relay 2 drops out when a malfunction occurs
3	Both alarm relays drop out when a malfunction occurs
4	Cooling off, both alarm relays remain closed when a malfunction occurs
5	System off, alarm relay 1 drops out when a malfunction occurs
6	Cooling off, alarm relay 2 drops out when a malfunction occurs
7	Cooling off, both alarm relays drop out when a malfunction occurs
8	Cooling off, alarm relay 1 drops out when a malfunction occurs

Tab. 9: Alarm relay function

- Cooling off: Compressor and fan OFF, pump ON
- System off: Pump, compressor, fan OFF

7.7 PLC outputs

The meanings of the settings for the PLC outputs are as follows:

- 0: No PLC output turned on
- 1...8: The relevant circuits of the PLC output may be found under tab. 8 "Error codes".

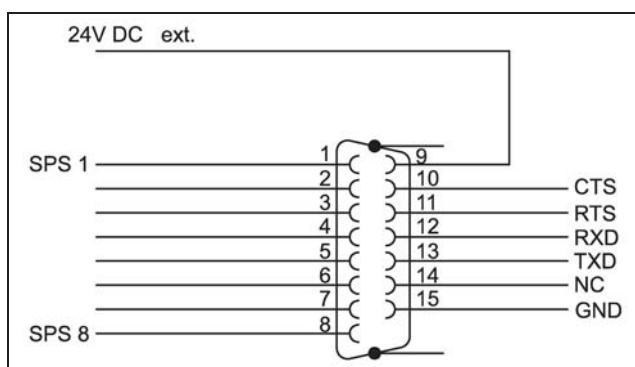

Fig. 58: PLC outputs

7.8 Setting the digital real-time clock



The micro controller box is fitted with an integral real-time clock. The current time can be set in menu P9 under "Time". It is also possible to switch between summer time and winter time. The clock is supplied with power by a lithium battery.

Clock control can be switched on and off and parameterised separately for cooling (P10, "Switching times, compressor") and heating mode (P11, "Switching times, heater"). If clock control is deactivated (P10 or P11, "OFF"), control occurs independently of the time. If clock control is activated (P10 or P11, "ON"), control only operates within the preset time intervals.

The time intervals may be set individually for each day of the week with a start time (hour/minute) and a stop time (hour/minute). Setting 6:00 to 18:00 means that the unit is only operational from 6.00 am to 6.00 pm. With a setting 20:00 to 5:00, the unit will operate from 8.00 pm till midnight (24.00 pm) and then from 0:00 to 5.00 am the next morning.

With clock control activated (P10 or P11, "ON"), after

pressing the  key, it is possible to set the day of the

week using the  and  keys (1=Monday to 7=Sunday). Press **Esc** to return to the parameter selection. The start and stop time can then be set one after the other in hh and mm.

8 Inspection and maintenance

EN

8 Inspection and maintenance

Proper, regular inspections and maintenance (once a year is recommended) and usage of original spare parts only are crucial for problem-free operation and a long service life of the chiller.

We therefore recommend a maintenance contract.

We offer maintenance service.

Our service contact:

Phone: +49 2772 505-1855

Fax: +49 2772 505-1850

E-mail: service@rittal.de



Danger!

Risk of electric shock at live connections!

Prior to any inspection and maintenance work, the chiller must be disconnected from the power supply.

Overview of the inspection and maintenance tasks

Assembly	Task	Interval
Compressor	No maintenance is necessary on the fully hermetic compressor.	–
Cooling medium level	Check for sufficient filling, top up if necessary.	1 week
Filter mat (option)	Clean or replace filter mat.	4 weeks
Cooling medium	Check cooling medium circuit for soiling and any foreign bodies (chips and the like).	4 weeks
Tank, components, and all connections (piping, valves and fittings, hoses) in the circuit for the equipment to be cooled	Check for leaks.	4 weeks
Condenser (air-cooled)	Clean fins using compressed air, or with a brush.	2 months
Condenser fan (air-cooled)	Check noise generation, clean.	6 months
Cooling medium	Replace cooling medium	1 year

Tab. 10: Inspection and maintenance tasks

Assembly	Task	Interval
Condenser (water-cooled)	Check for adequate flow rate.	1 year
Refrigerant circuit	Have refrigerant circuit checked by a specialist refrigeration company.	1 year

Tab. 10: Inspection and maintenance tasks

8.1 Maintaining the refrigerant circuit

As a hermetically sealed system, the refrigerant circuit has been filled in the factory with the required amount of refrigerant, tested for leaks and subjected to a function test run.

Maintenance tasks on the refrigerant circuit are only allowed to be undertaken by a specialist refrigeration company. We recommend a maintenance contract that includes an annual inspection of the refrigerant circuit (European regulation EC no. 517/2014 / fluorinated greenhouse gases).

8.2 Cooling medium

8.2.1 General remarks

When cooling the water-glycol mixture in an open circuit, always remember that algae, deposits and corrosion can damage the chiller. Residues will always impair the performance of the chiller. Without water treatment it is only seldom possible to achieve satisfactory conditions. By means of regular monitoring of the quality of the cooling medium and cooling medium treatment, you must ensure that deposits and corrosion are avoided, even under extreme conditions.

8.2.2 Cooling medium requirements

The cooling medium must not cause any limescale deposits or loose debris. In other words, it should have a low level of hardness, particularly a low level of calcium hardness. In particular, the level of calcium hardness should not be too high when using the equipment for recirculated cooling. On the other hand, the cooling medium should not be so soft that it attacks the materials. When recooling the cooling medium, the salt content should not be allowed to increase excessively due to the evaporation of large quantities of water, since the electrical conductivity will increase as the concentration of dissolved substances rises, and the cooling medium will become more corrosive. For this reason, not only is it always necessary to add a corresponding quantity of fresh water, but also to remove part of the enriched cooling medium.

Furthermore, the properties of the water used must not deviate from the following list of hydrological data:

Properties	Value
p _H value	(7) 7.5 – 8.5
Electrical conductivity	200 – 1000 µS/cm
Residue on evaporation	< 500 mg/dm ³
Sedimentary substances	< 3 mg/dm ³
Hardness	3 – 8°dH (for German-speaking regions)
Ca + Mg	0.5 – 2 mmol/l (for international region)
Hydrogen carbonate	1 – 5 mmol/dm ³ (60 – 300 mg/dm ³)
Free CO ₂	< 10 mg/dm ³
Sulphide	< 0.01 mg/dm ³
Chloride	< 50 mg/dm ³
Sulphate	< 250 mg/dm ³
Nitrate	< 25 mg/dm ³
Nitrite	< 0.1 mg/m ³
COD	< 7 mg/dm ³
NH ₄	< 0.05 mg/dm ³
Fe	< 0.1 mg/dm ³
Mn	< 0.1 mg/dm ³
Cu	< 0.1 mg/dm ³

Tab. 11: Hydrological data



Note:

The cooling medium thickens due to evaporation. You can return the values to within the usual ranges by completely replacing the cooling medium. Only use distilled or de-ionised water in chillers specified for such use (see data sheet in section 12.4 "Technical specifications").

8.2.3 Preparation and care

There are specific cooling medium requirements depending on the type of equipment being cooled. A suitable process must then be used to prepare and/or maintain the cooling medium to suit the level of contamination and the size and design of the chiller. The most common types of contamination and most frequently used techniques to eliminate them in industrial cooling are shown in the following table:

Type of impurity	Removal
Mechanical contamination	Filtering of the cooling medium via mesh filter, gravel filter, cartridge filter, or pre-coated filter
Excessive hardness:	Softening of the cooling medium using ion exchange
Moderate content of mechanical contaminants and hardeners	Addition of stabilisers and/or dispersing agents to the water
Moderate levels of chemical contaminants	Addition of passifiers and/or inhibitors to the cooling medium
Biological contaminants, slime bacteria and algae	Addition of biocides to the cooling medium

Tab. 12: Impurities and removal

8.2.4 Recommended "Cooling medium for chillers"

Rittal recommends the use of "Cooling medium for chillers" (water-glycol mixture). This is a ready-mixed solution and is therefore suitable for immediate use (without the need for mixing) (tab. 13 and tab. 14).

Composition

Glycol (20-30% max.) + water (70-80% max.) = ready-mix ("Cooling medium for chillers")

Model No.	Quantity [l]	Application
3301.950	10	Outdoor
3301.960	10	Indoor
3301.955	25	Outdoor
3301.965	25	Indoor

Tab. 13: Model numbers – Cooling medium for chillers



Note:

When glycol is used, the cooling performance is reduced, depending on the glycol concentration (tab. 14).

8 Inspection and maintenance

EN

Cooling medium for chillers	Temp. [°C]	Loss of cooling performance compared with pure water [%]
Standard (20% glycol) Antifreeze: -10°C	10	-6
	15	-6
	18	-6
Outdoor (30% glycol) Antifreeze: -20°C	10	-13
	15	-13
	18	-13

Tab. 14: Performance loss

8.2.5 Monitoring the cooling medium

- Regularly check the level in the cooling medium tank.
 - **Types 3320.600, 3334.600, 3334.660**
At the fill level display (fig. 3 or fig. 5, item 3).
 - **Types 3360.100, 3360.250, 3360.470**
At the fill level display (fig. 7 to fig. 9, item 3).
- Regularly check the quality of the cooling medium, and if necessary, improve it as described under section 8.2.3 "Preparation and care".
- Regularly measure the glycol content with the aid of a refractometer (fig. 59). If you have any questions about this, please contact our service department.
- In order to prevent the formation of fungus and algae, the cooling medium should be replaced at least once a year. The use of pure water may also cause the formation of fungus or algae.

If the chiller is used under certain physical conditions ($T_w < 10^\circ\text{C}$), condensation may form in the system. This can be minimised by means of suitable insulation or the optionally available room-temperature-based control.



Fig. 59: Refractometer



Note:

The manufacturer's guarantee and liability will be rendered void in cases of incorrect use and treatment of the chiller. To prevent problems in the cooling medium circuit (including water-cooled chillers), it is imperative that the VGB Cooling Water Guidelines (VGB-R 455 P) are observed.

8.3 Cleaning the condenser

The entire condenser is covered in a dirt-repellent, easy-to-clean RiNano coating. In many applications, there-

fore, the use of filter media is unnecessary, particularly with dry dusts.

To ensure the correct function of the chiller, the fins on the air-cooled condenser must be kept clean. Cleaning must be undertaken at regular intervals of at least once per half year; the frequency of cleaning depends on the degree of soiling in the rooms where the unit is installed. Ambient air containing oil in conjunction with dust will result in increased soiling of the condenser fins. In such cases, thorough cleaning with compressed air is only possible under certain circumstances. In such cases, the additional use of a metal filter mat is required (see section 5.7 "Installing the filter mats (accessories)").

When cleaning, it is imperative to observe the following warning and safety notes below.



Danger!

Prior to any inspection and maintenance work, the chiller must be disconnected from the power supply.



Danger!

Temperatures of up to 60°C may occur inside the chiller. Wait approx. 10 min. after you have switched off the chiller to allow the pipe to cool down.



Risk of cuts!

Risk of injury due to sharp-edged condenser fins! Use gloves as personal protection equipment.



Caution!

Risk of damage for the condenser fins due to powerful compressed air! Use the compressed air carefully to avoid damage.

When cleaning, please proceed as follows:

- Deactivate the chiller by switching off the power supply to the higher level control and secure against switching back on.
- Remove the louvred grille (fig. 60, item 2) on the front of the chiller.

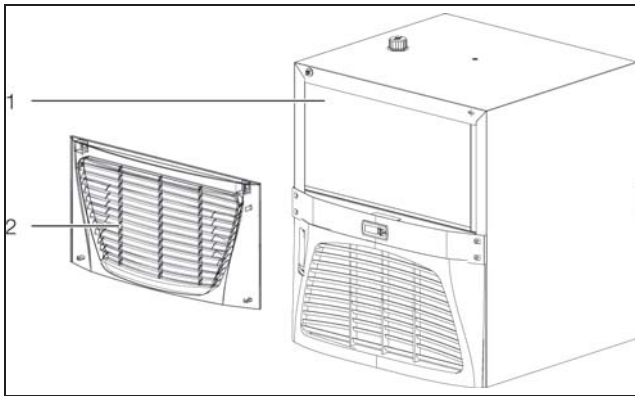

Fig. 60: Cleaning the condenser (shown here: 3320.6xx and 3334.6xx)

- Clean the condenser (fig. 60, item 1) with compressed air.

8.4 Cleaning the filter mat (accessories)

Types 3318.600, 3318.610 and 3319.600, 3319.610, 3360.100, 3360.250, 3360.470



Danger!

Danger of injury due to rotating fan blades! Do not remove the louvred grille until after the condenser fan has come to a stop.

- Remove the louvred grille on the front of the chiller by carefully pulling it off the housing.
The louvred grilles are fastened onto the housing with plastic pins.
- Remove the filter mat from the louvred grilles.
- Clean the metal filter mats with a high-pressure cleaner.
- Place the cleaned metal filter mat in the louvred grille and press it back into the housing.

Types 3320.600, 3334.600 and 3334.660

The louvred grilles are fastened onto the housing with plastic pins.



Danger!

Danger of injury due to rotating fan blades! Do not remove the louvred grille until after the condenser fan has come to a stop.

- Remove the upper louvred grille on the rear of the chiller by carefully pulling it off the housing.
- Pull the filter mat upwards out of the chiller.
- Clean the metal filter mats with a high-pressure cleaner.
- Press the upper louvred grille back onto the housing.

8.5 Draining the cooling medium tank

- Drain the cooling medium tank via the tank drain nozzle (fig. 2 to fig. 9, item 7) either directly or using a hose into a container.



Note:

To drain the cooling medium tank on models 3318.610 and 3319.610 we suggest installing an external discharge appliance at the cooling medium output. If you don't have such a discharge appliance installed you have to loosen the piping (at the cooling medium output) to drain the medium tank.

- When disposing of the cooling medium, observe the locally application regulations on water pollution.

9 Troubleshooting

In operation, the chiller operates in a safe state. The chiller maintains the cooling medium inlet temperature at the setpoint set.

Possible causes for deviation from the setpoint could be:

- Cooling demand too high
- Ambient temperature too high
- Failure to observe required distances
- Soiled evaporator
- Soiled condenser
- Lack of refrigerant
- Level of cooling medium in tank too low (not with pressure-sealed chillers)
- Cooling medium temperature set too low
- Parameters set incorrectly

The malfunctions are only allowed to be rectified by suitably instructed, qualified personnel.

For information on malfunction analysis, refer to tab. 8 "Error codes" or contact our service department:

Service contact:

Rittal International Service
Auf dem Stützelberg
35745 Herborn

Phone: +49 2772 505-1855

Fax: +49 2772 505-1850

E-mail: service@rittal.de

10 Decommissioning and disposal

The chiller is only allowed to be shut down by authorised, qualified personnel. For this purpose the chiller must be decommissioned.

- Electrically isolate the chiller by disconnecting it from the power supply.

10.1 Decommissioning

If the chiller is not to be used for an extended period (more than 6 months) the cooling medium circuit must be drained. This will prevent the evaporation of water, and the water-glycol ratio of the cooling medium will not be altered. If the glycol concentration increases, the pump seal may be irreparably damaged.

- Disconnect the chiller from the supply of power and secure it against switching back on.
- Disconnect the cooling medium circuit connections.
- For disposal of the cooling medium, observe the applicable regulations on water pollution, in Germany the Wasserhaushaltsgesetz (Federal Water Act).
- Drain the cooling medium circuit as described in section 8 "Inspection and maintenance".
- To recommission the chiller, proceed as described in section 6 "Commissioning". Make the same checks as described in that section.

10.2 Disposal



Caution!

Risk for the environment! Intentional release of the refrigerant is strictly prohibited. Refrigerant must be disposed of properly.

- Decommission the chiller (see section 10.1 "Decommissioning").
- Notify your supplier or our service department for proper disposal of the chiller.

Certificate in accordance with BGR 500 chap. 2.35 and DIN EN 378-2 on the inspection of a cooling system



Note:

If a system is changed or taken out of operation for more than 2 years, it is to be re-inspected and a new certificate issued. A system has been modified:

- if a system is opened and converted to a different refrigerant,
- if stationary system is moved elsewhere,
- if an existing system is extended or converted
- or major improvements are carried out.

11 Accessories

EN

11 Accessories

11.1 Connection set for air/water heat exchangers

The connection set is used to ensure professional laying of water connections between chiller and air/water exchanger. The pressure hoses (L = 3.60 m) may be cut to length individually, depending on the application.

Supply includes:

- Hose for water return
- Hose for water inlet including regulator valve for regulating the volumetric flow (setting range 3 to 12 l/min)
- Assembly parts



Fig. 61: Connection set

Material	Packs of	Model No.
Water-carrying parts EPDM/brass	1	3201.990

Tab. 15: Connection set for air/water heat exchangers

11.2 Flow regulator valve

For use with air/water heat exchangers, especially if more than one heat exchanger ($n > 1$) is used in the water cooling circuit. The correctly set valve then ensures the same quantity of cooling medium for all equipment. The valve is used for hydraulic balancing.

- Material: Brass
- Setting range: 3 – 12 l/min



Fig. 62: Flow regulator valve

Version	Packs of	Model No.
G 3/4" x Rp 1/2" for volumetric flow control	1	3301.930
G 3/4" x Rp 1/2" for volumetric flow control	1	3301.940

Tab. 16: Flow regulator valve

11.3 Metal filter (aluminium filter)

Particularly when chiller units are used in dusty and oil-laden environments, it is advisable to use washable metal filters. If air or steam condenses on the metal surfaces, any particles that may be present will adhere to the metal and are easily washed out with water or grease-dissolving detergents.

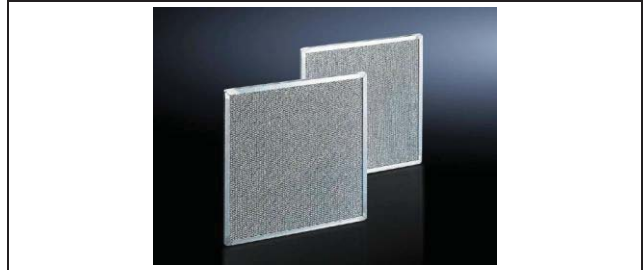

Fig. 63: Metal filters

Chiller	Packs of	Model No.
3318.600-609 / 3318.610-619 / 3319.600-609 / 3319.610-619	1	3286.510
3320.600-609 / 3334.600-609	1	3286.520
3334.660-669	1	2 x 3286.510
3360.100-109 / 3360.250-259 / 3360.470-479	1	3286.410

Tab. 17: Metal filters

11.4 Cooling medium for chillers (ready-mix)

Chiller systems are only suitable for the cooling of a water/glycol mixture. As well as protecting against frost, this cooling medium also serves to inhibit bacterial growth and provide optimum corrosion protection.



Fig. 64: Cooling medium for chillers (ready-mix)

Mixing ratio	Content	Model No.
1:4 (indoor)	10 l	3301.960
	25 l	3301.965
1:4 (outdoor)	10 l	3301.950
	25 l	3301.955

Tab. 18: Cooling medium for chillers (ready-mix)

11.5 Levelling feet

To compensate for height differences with floor irregularities.



Fig. 65: Levelling feet

Mounting thread	Adjustment height	Model No.
M12	18 – 43 mm	4612.000

Tab. 19: Levelling feet

11.6 Twin castors

With the help of twin castors the chiller can be moved and thus used at different production locations.



Fig. 66: Twin castors

Mounting thread	Maximum admissible static load (per castor)	Model No.
M12	75 kg	6148.000

Tab. 20: Twin castors

12 Appendix

12.1 P+ID diagram

Explanations of the abbreviations used may be found in the spare parts list for the relevant type.

Types 3318.600, 3319.600

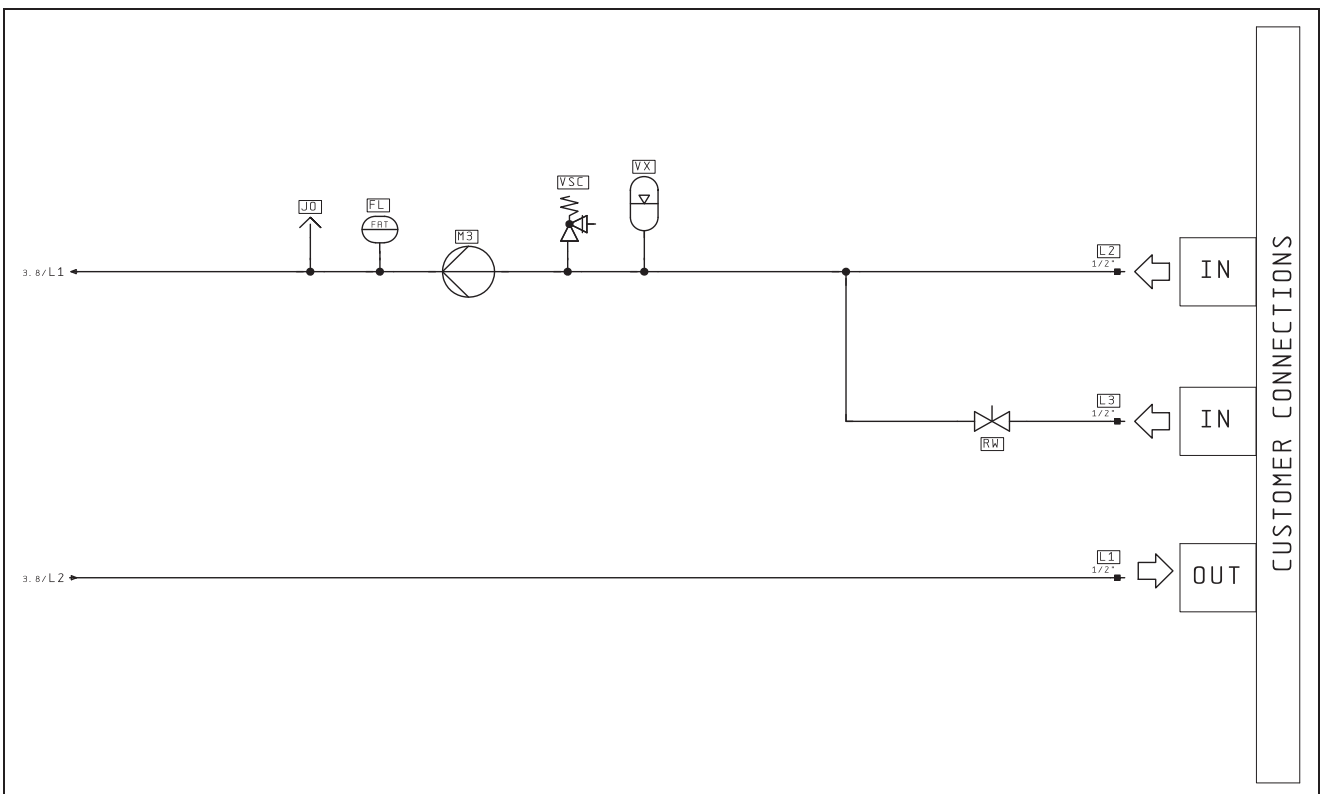
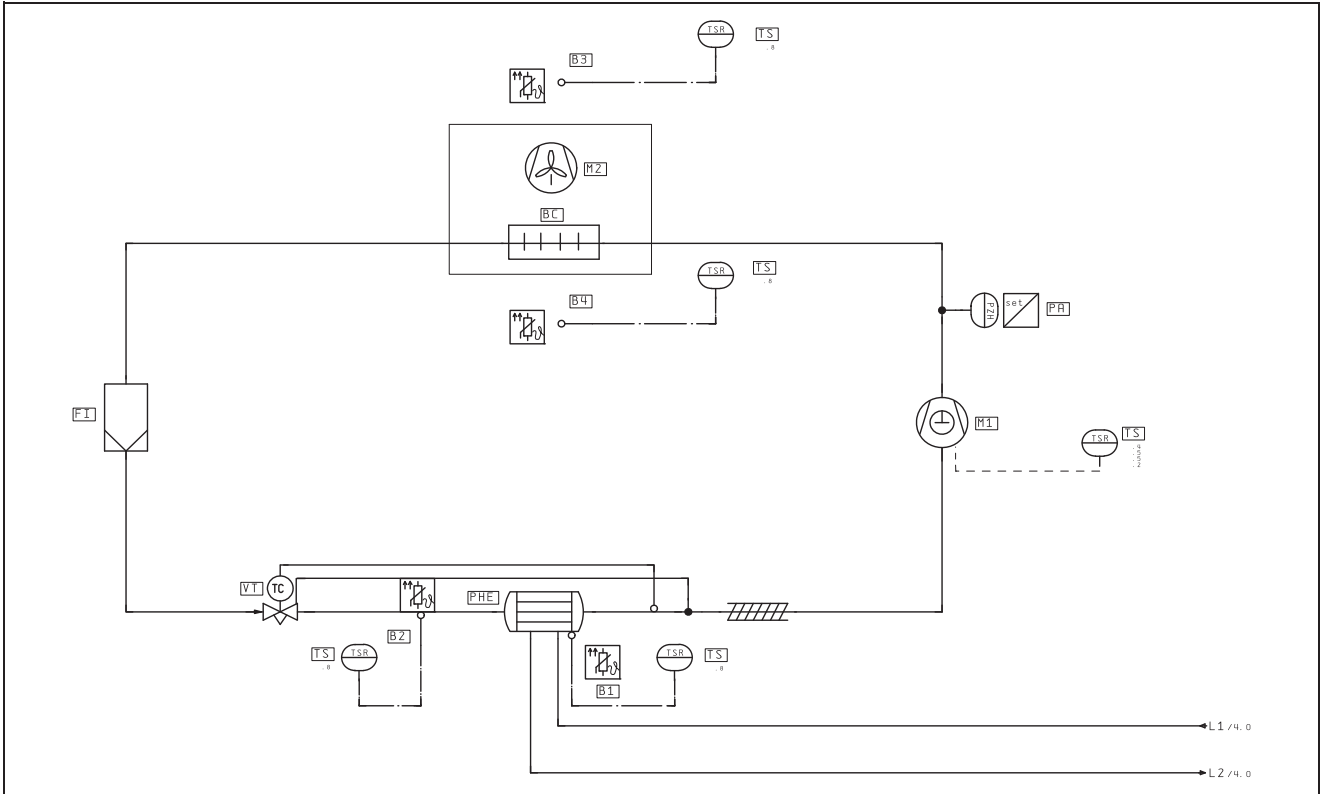

Fig. 67: Types 3318.600, 3319.600

Types 3318.610, 3319.610

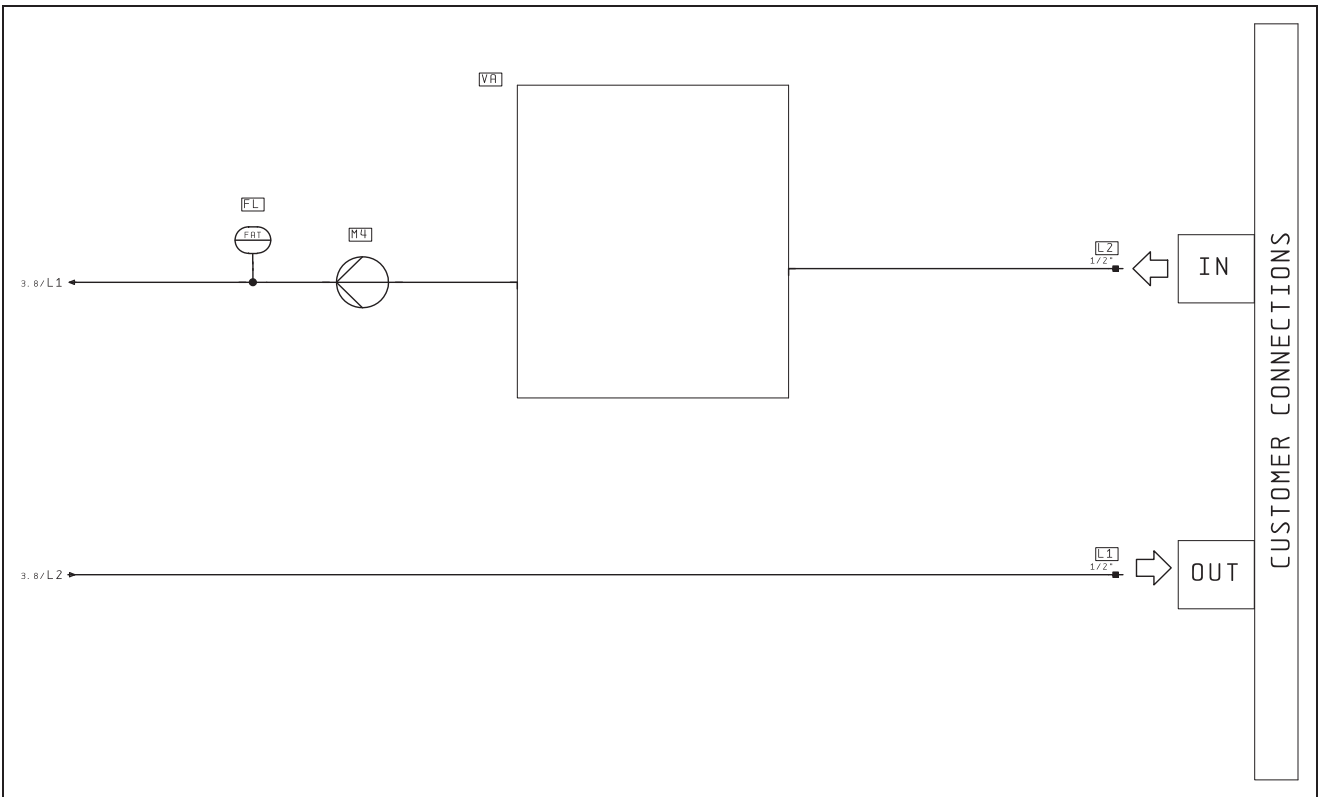
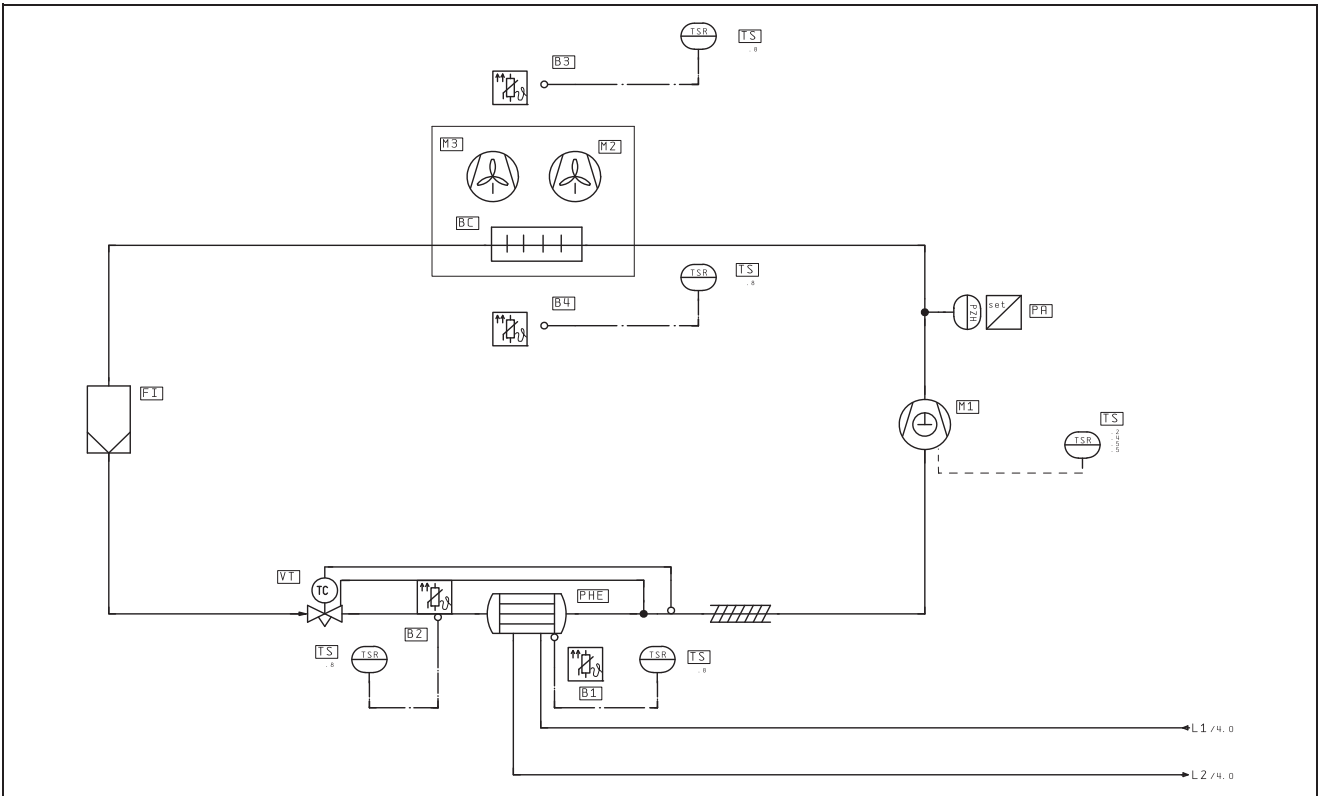

Fig. 68: Types 3318.610, 3319.610

12 Appendix

EN

Type 3320.600

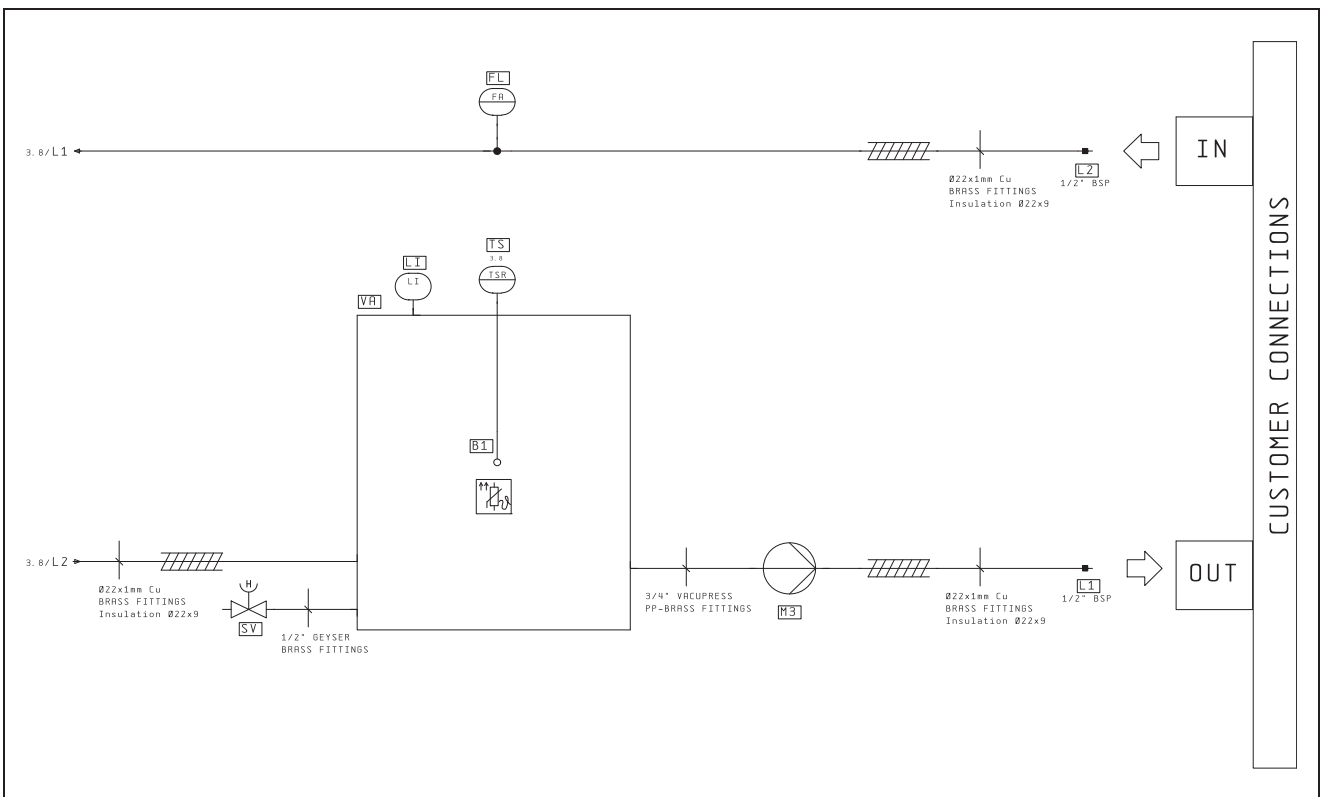
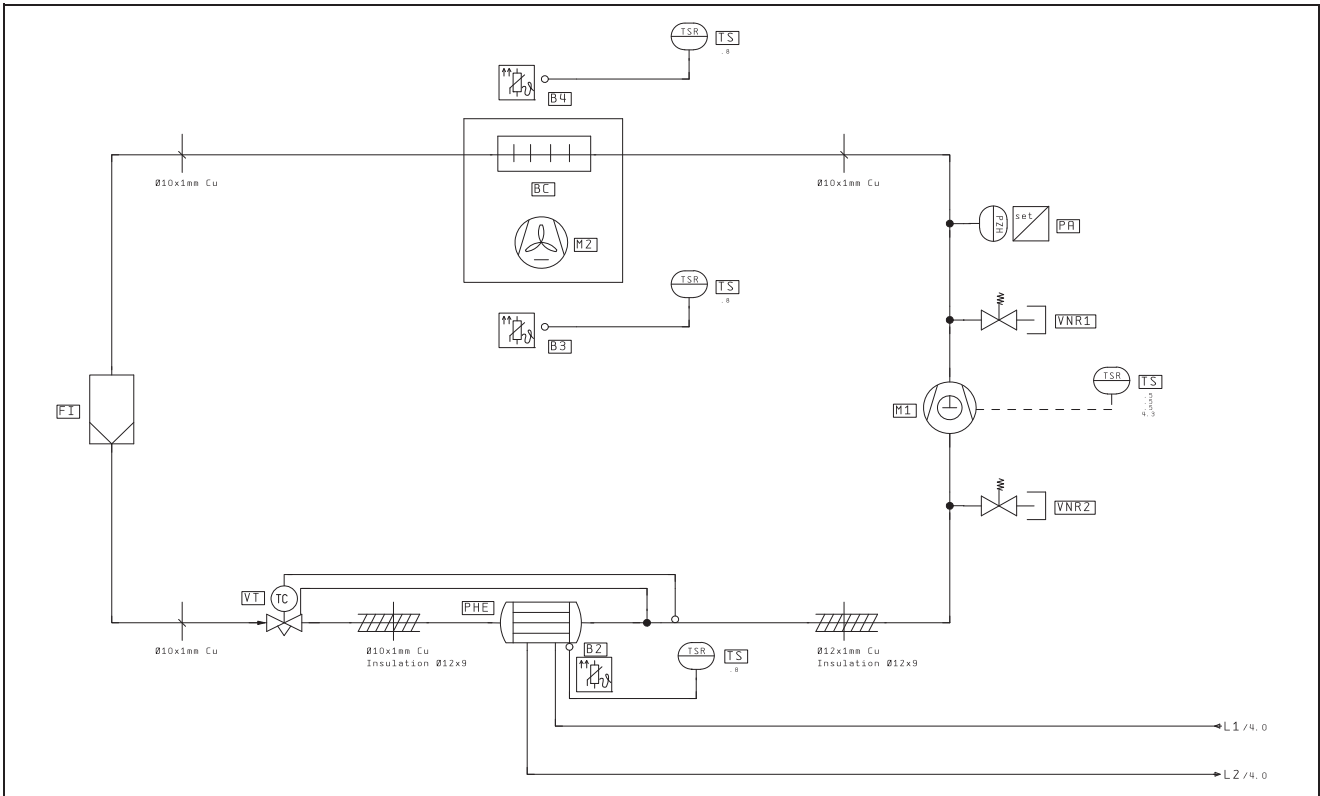

Fig. 69: Type 3320.600

Type 3334.600

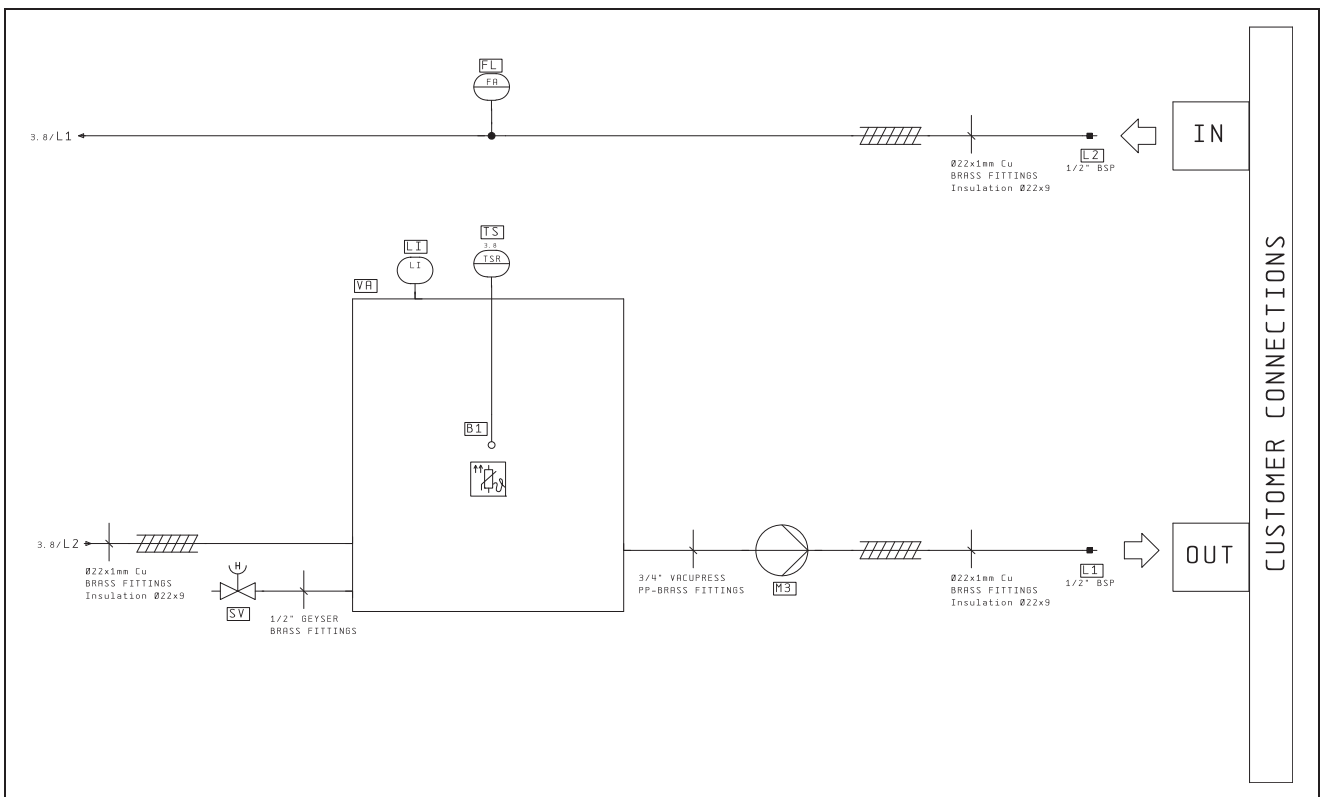
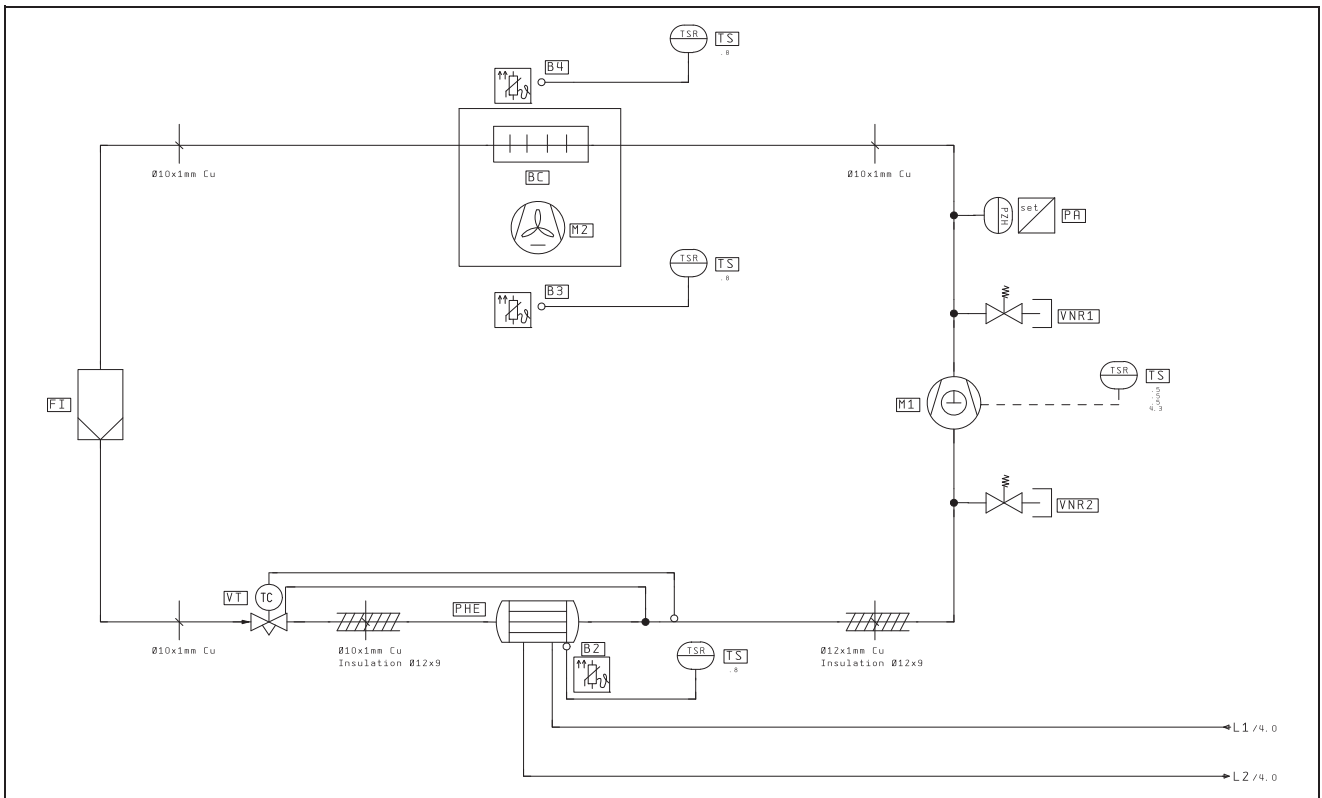

Fig. 70: Type 3334.600

12 Appendix

EN

Type 3334.660

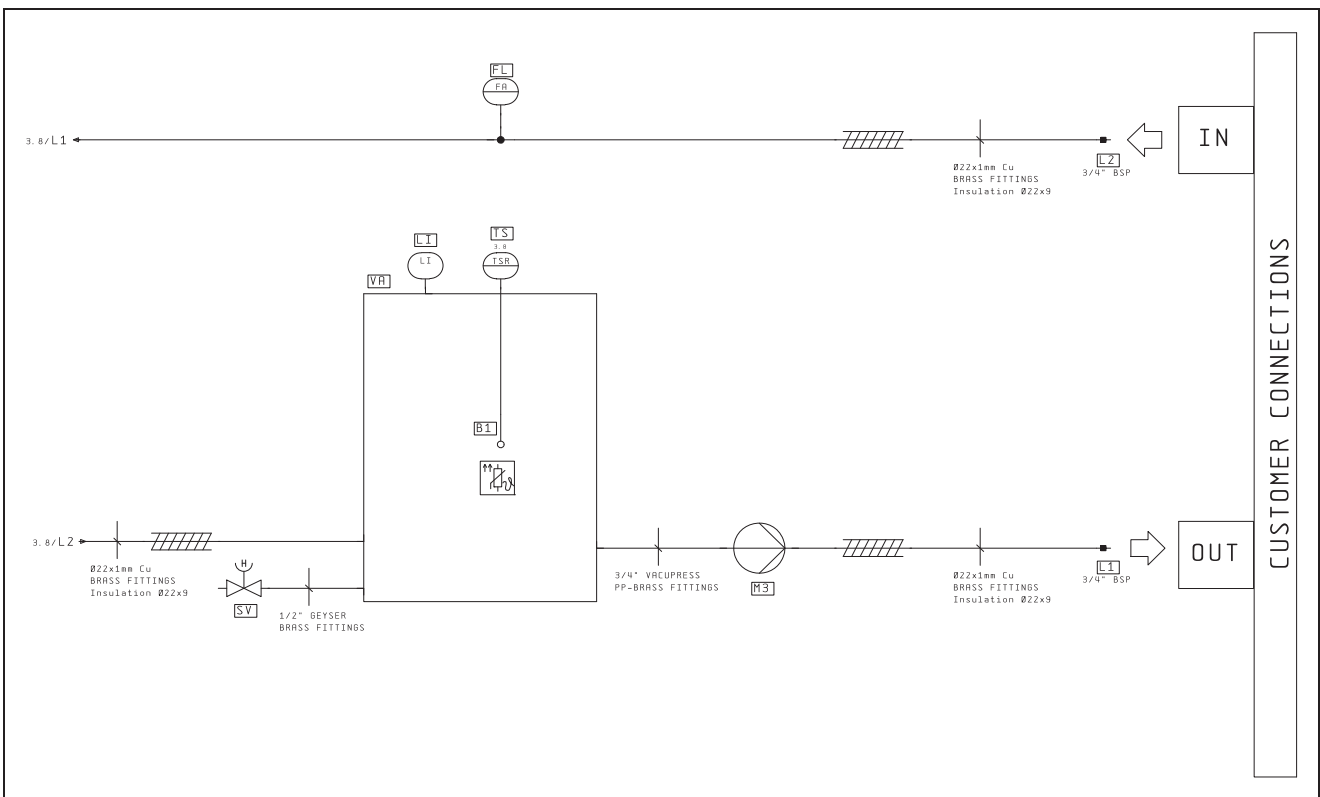
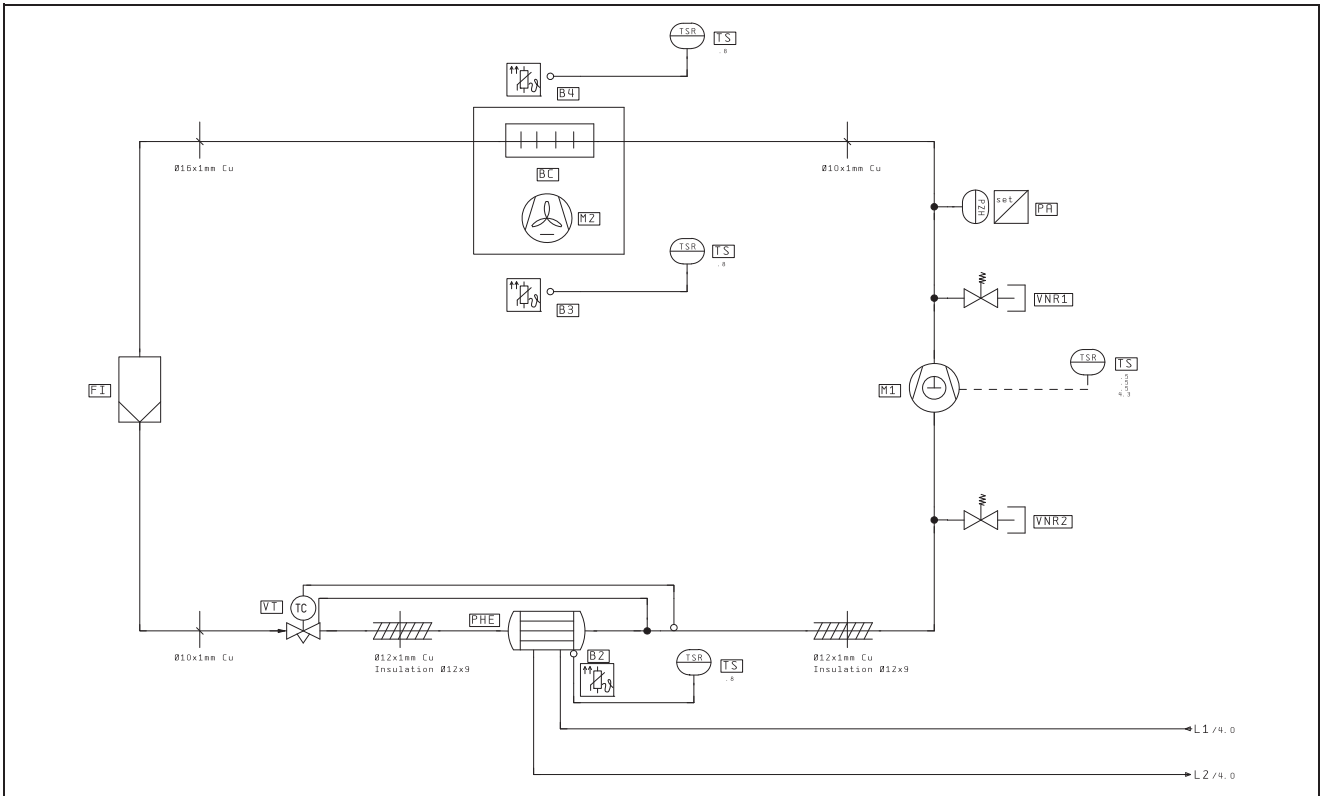

Fig. 71: Type 3334.660

Type 3360.100

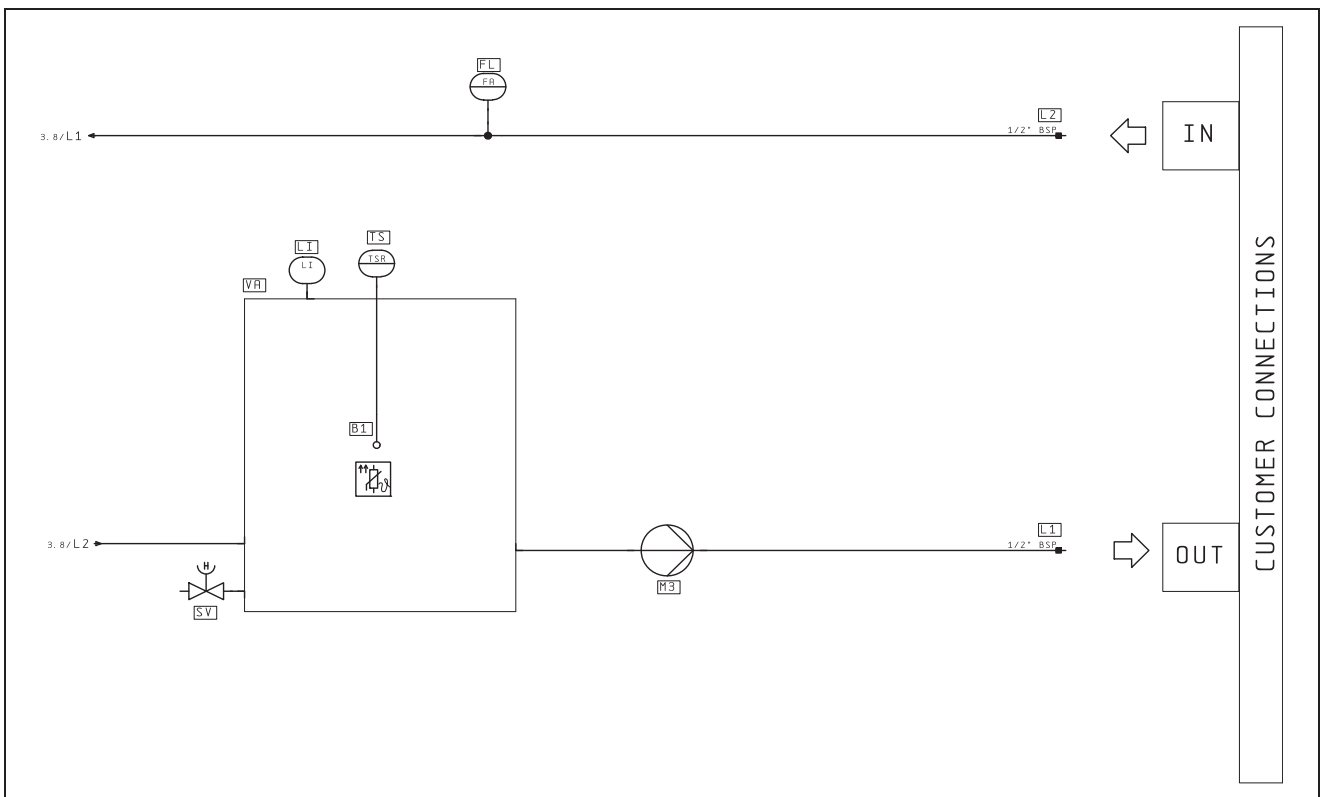
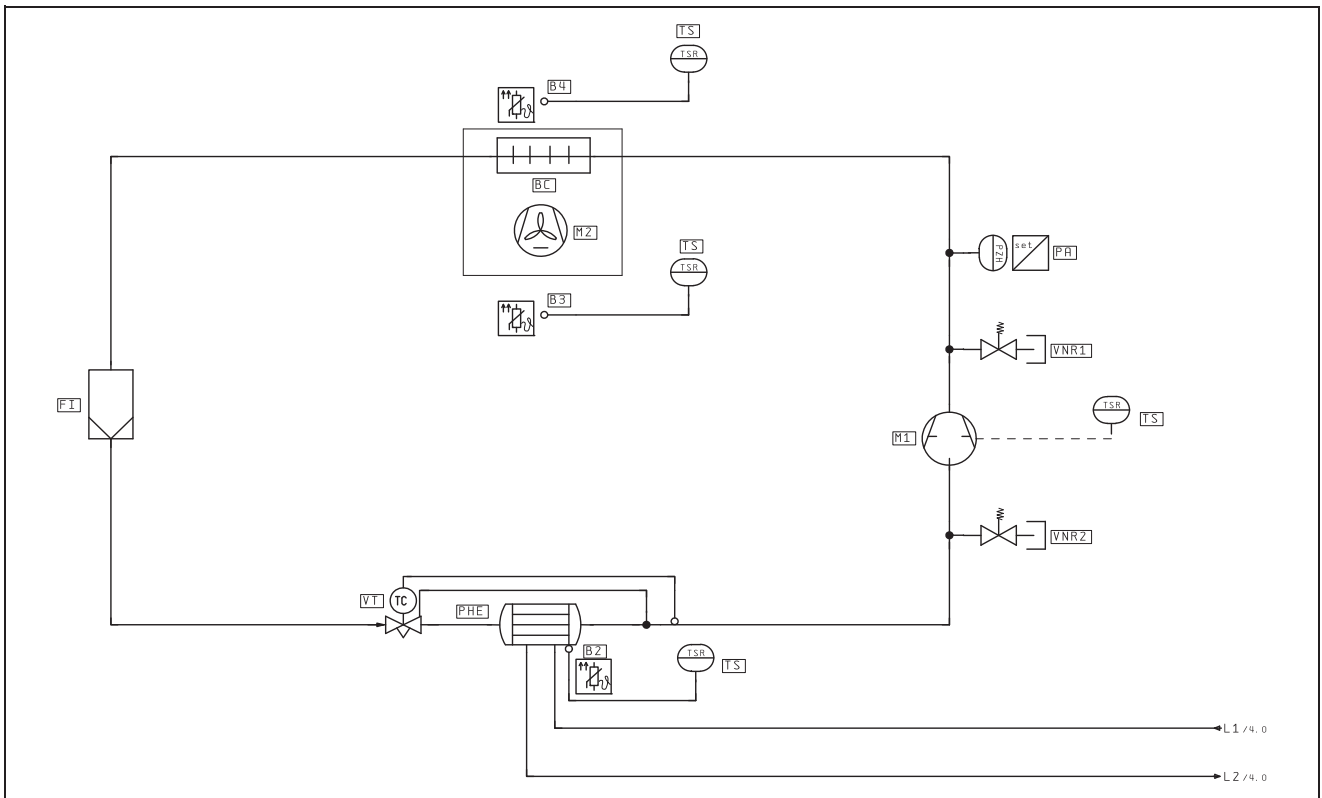

Fig. 72: Type 3360.100

12 Appendix

EN

Type 3360.250

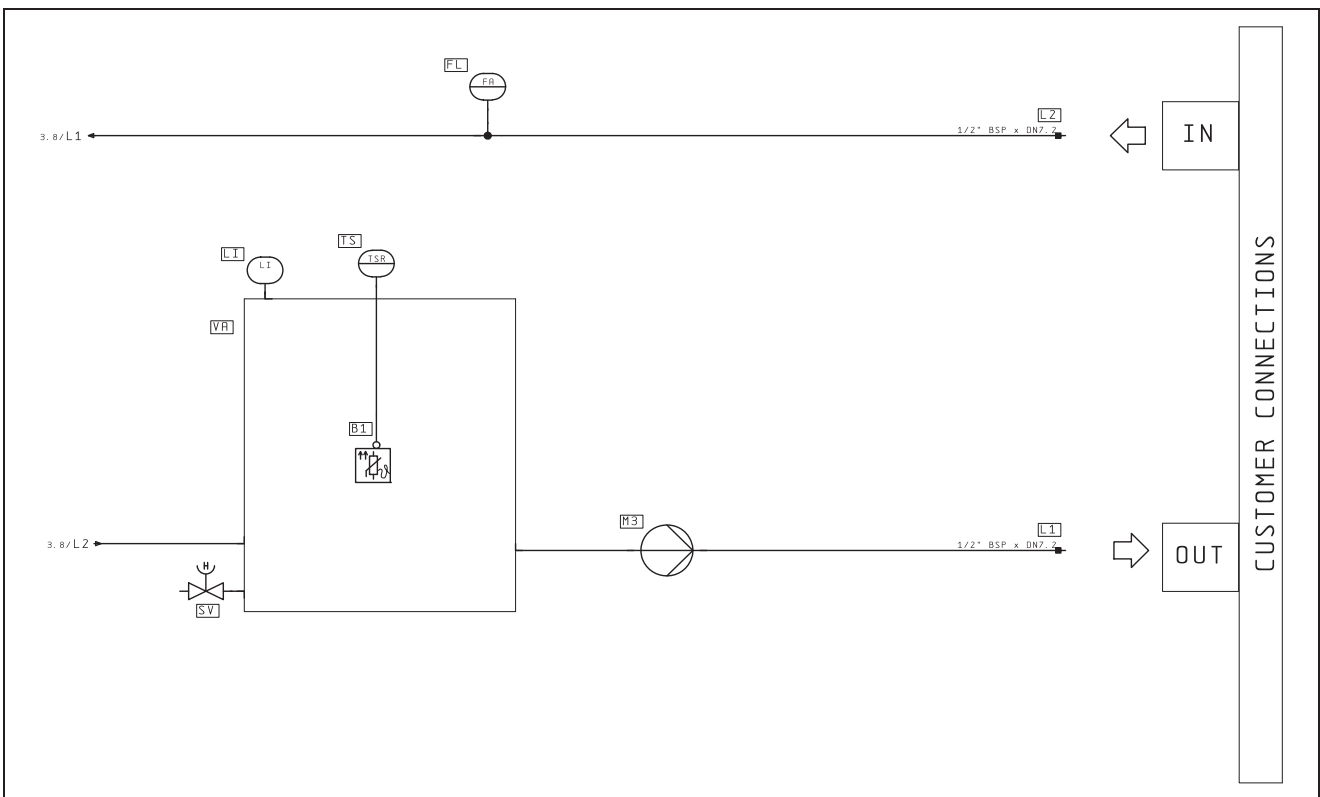
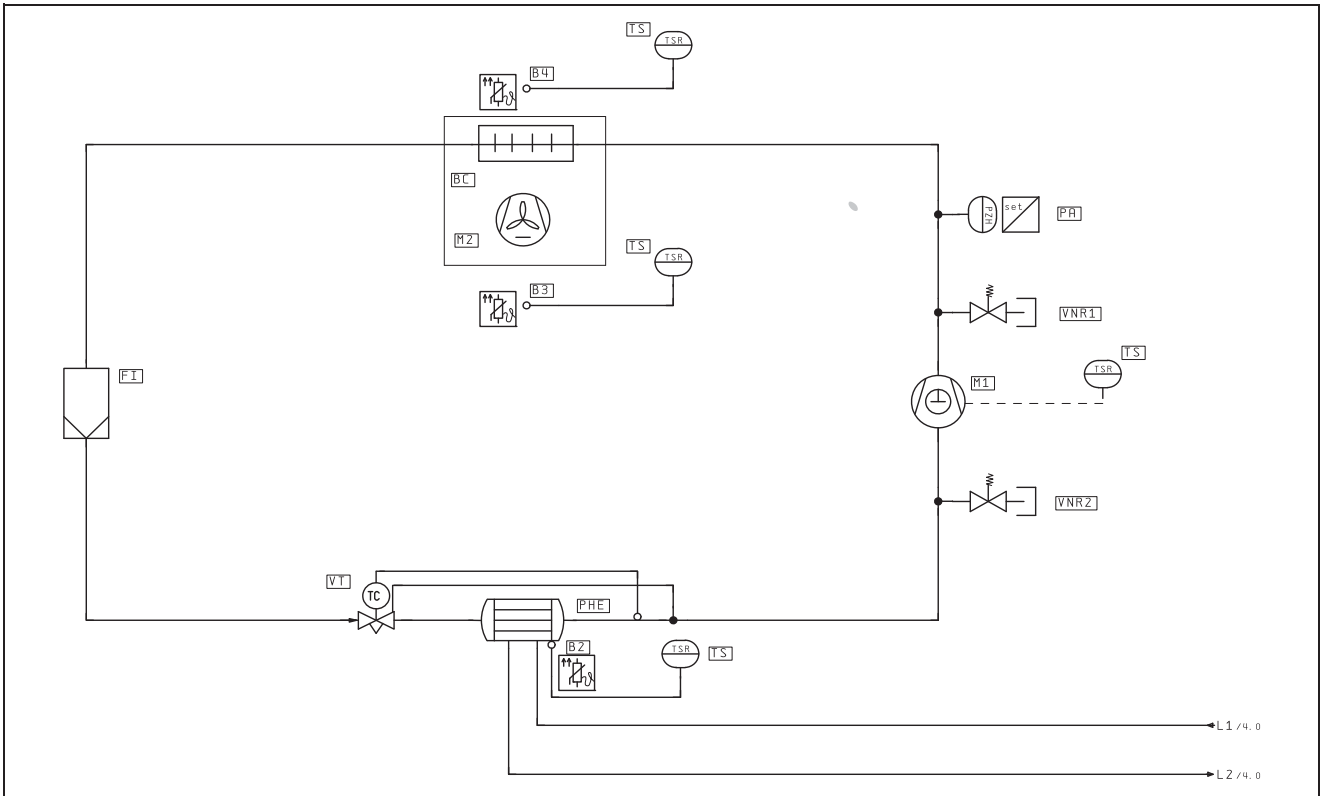

Fig. 73: Type 3360.250

Type 3360.470

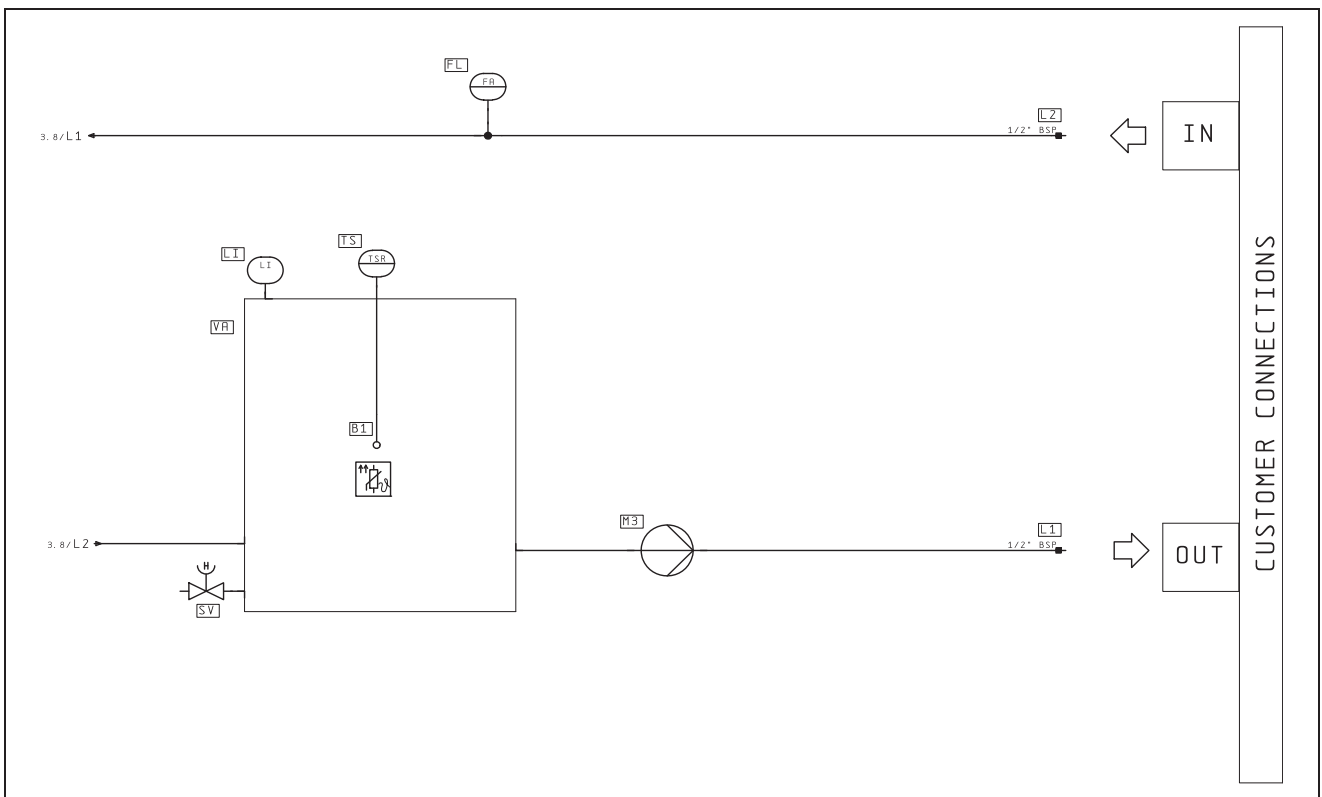
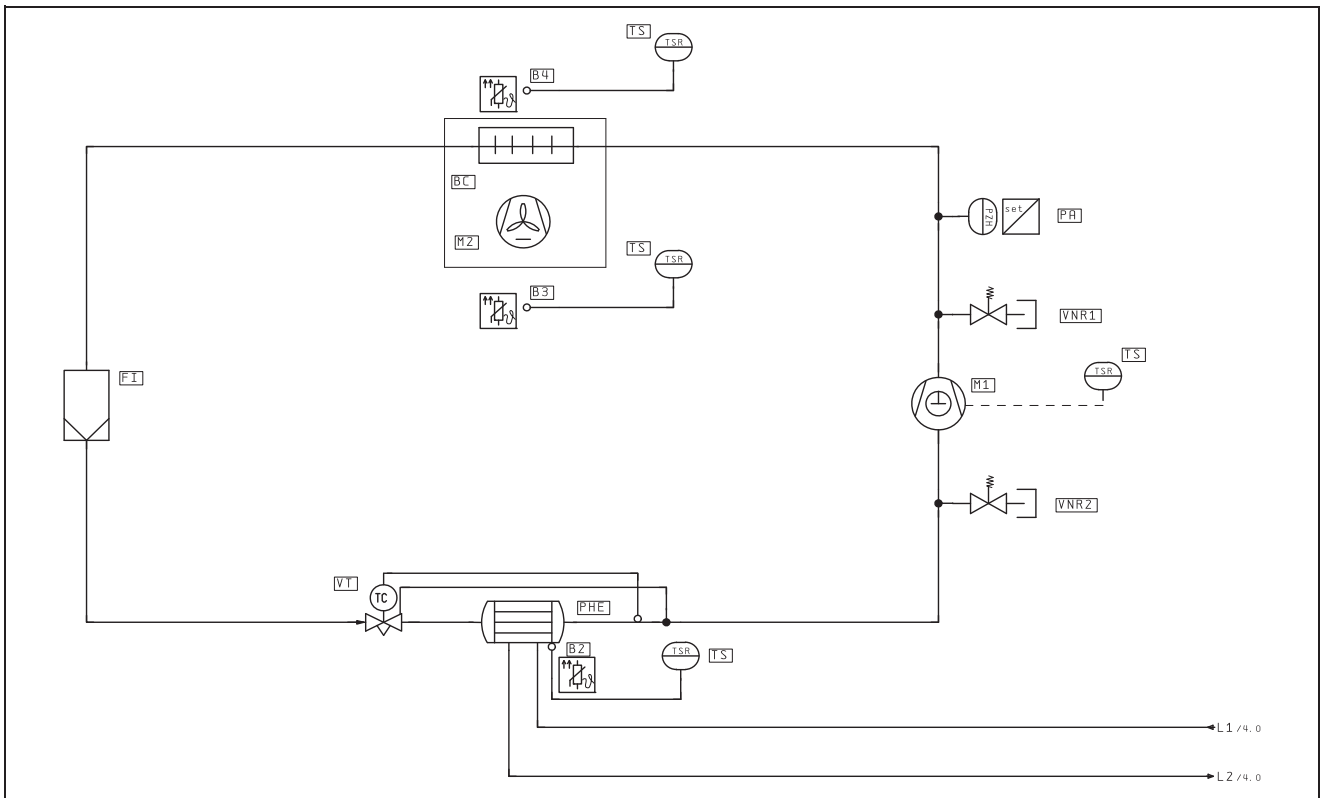

Fig. 74: Type 3360.470

12.2 Electrical circuit diagram

Types 3318.600, 3318.610 and 3319.600, 3319.610

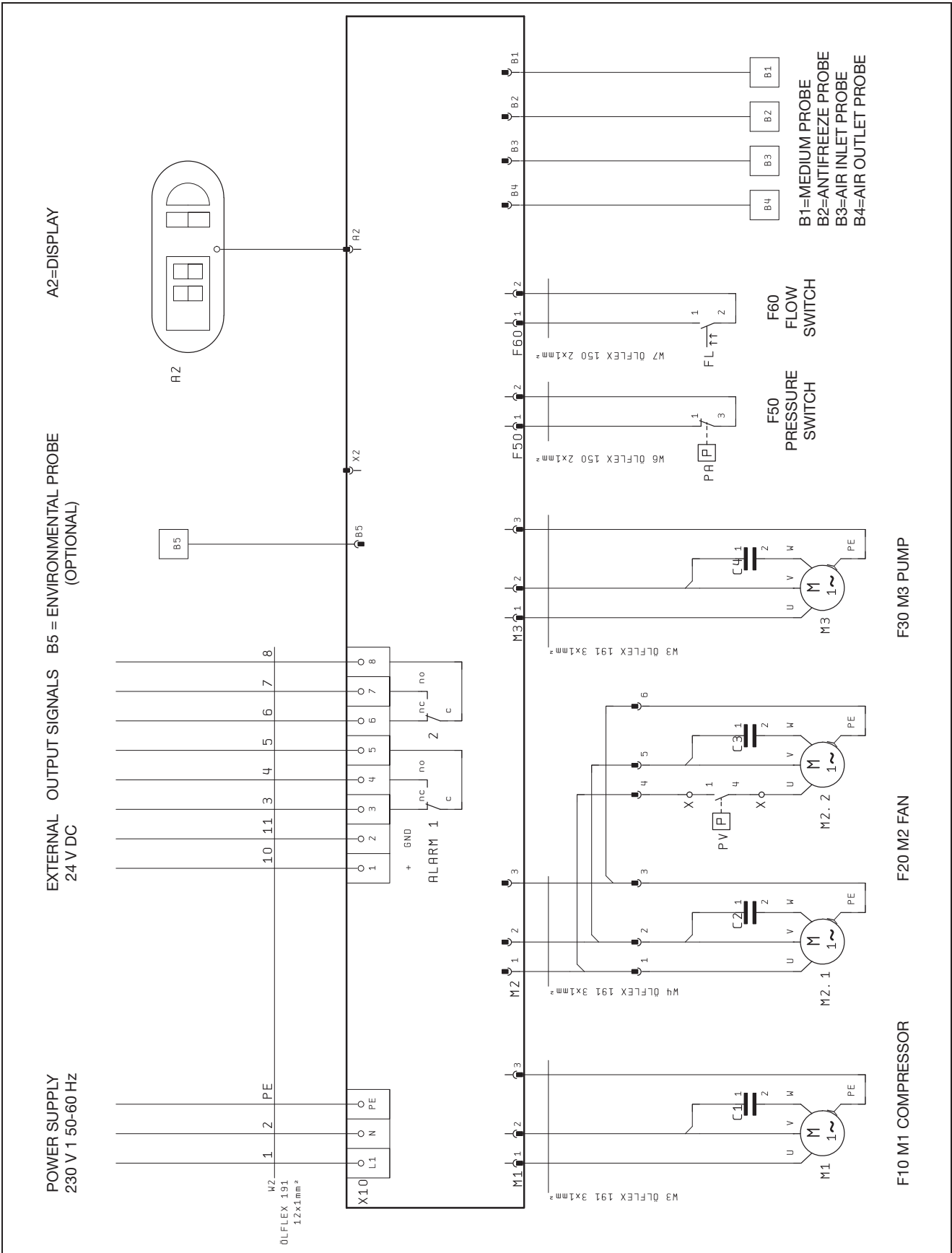

Fig. 75: Types 3318.600, 3318.610 and 3319.600, 3319.610

Types 3320.600, 3334.600, 3360.100, 3360.250

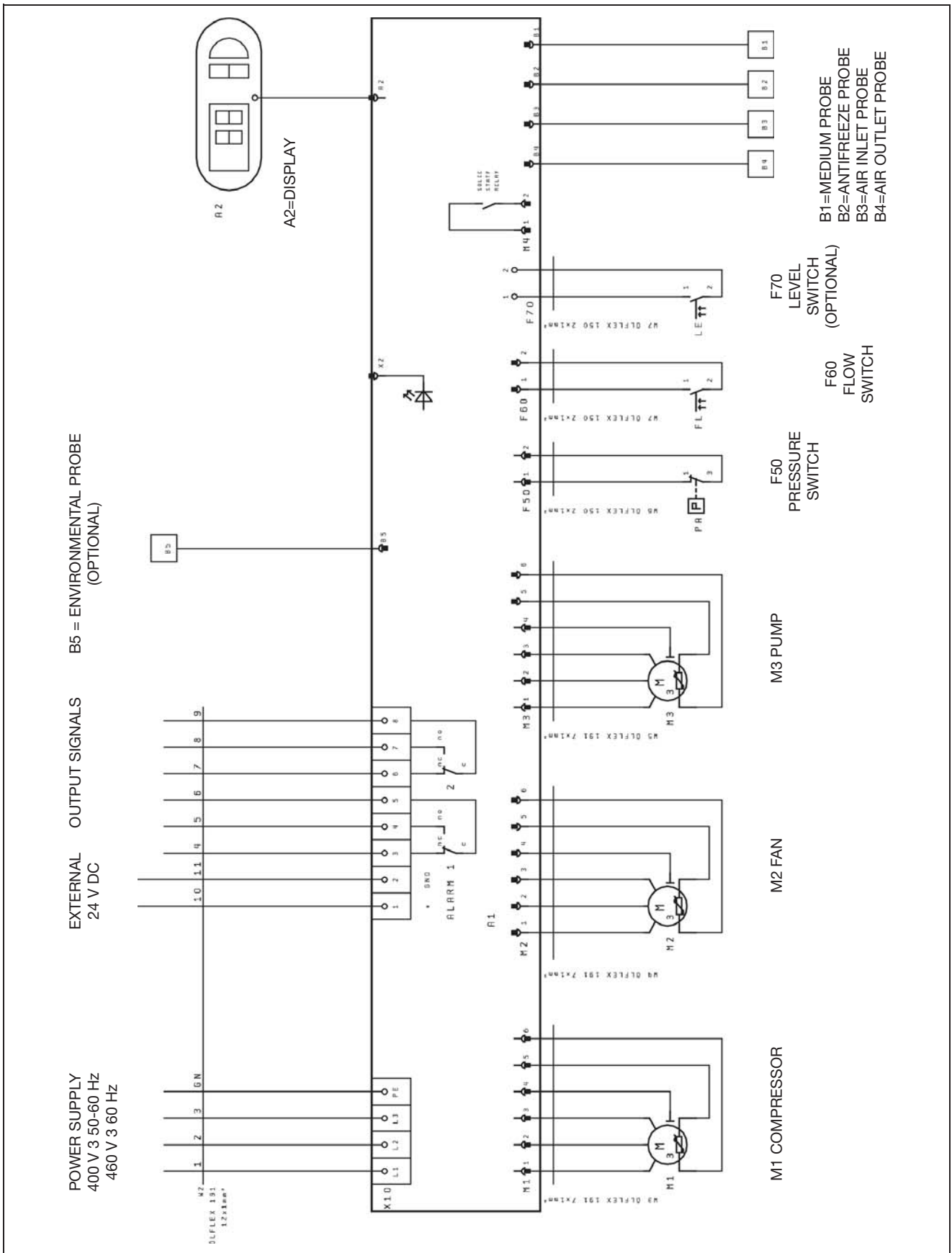

Fig. 76: Types 3320.600, 3334.600, 3360.100, 3360.250

Type 3334.660

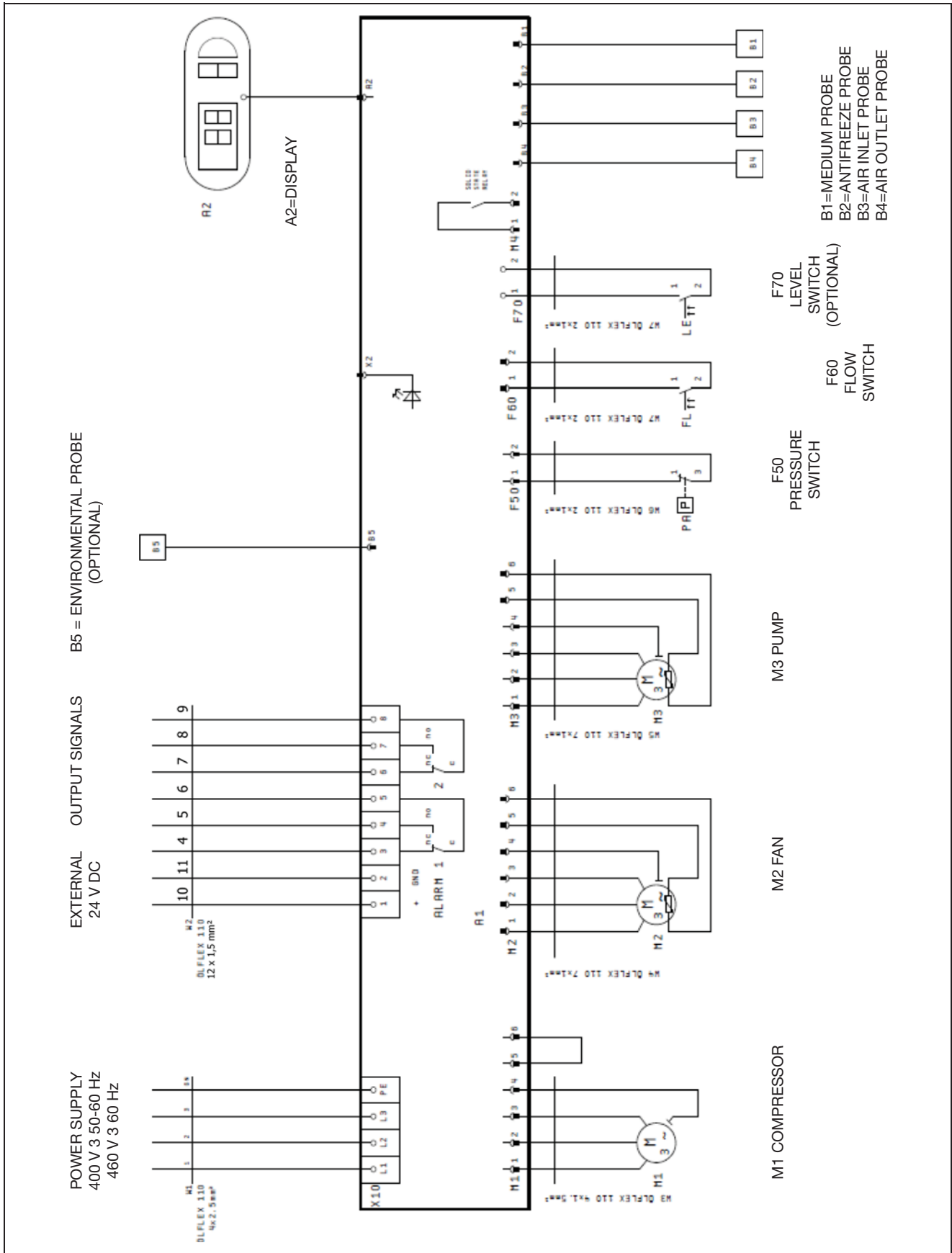

Fig. 77: Type 3334.660

Type 3360.470

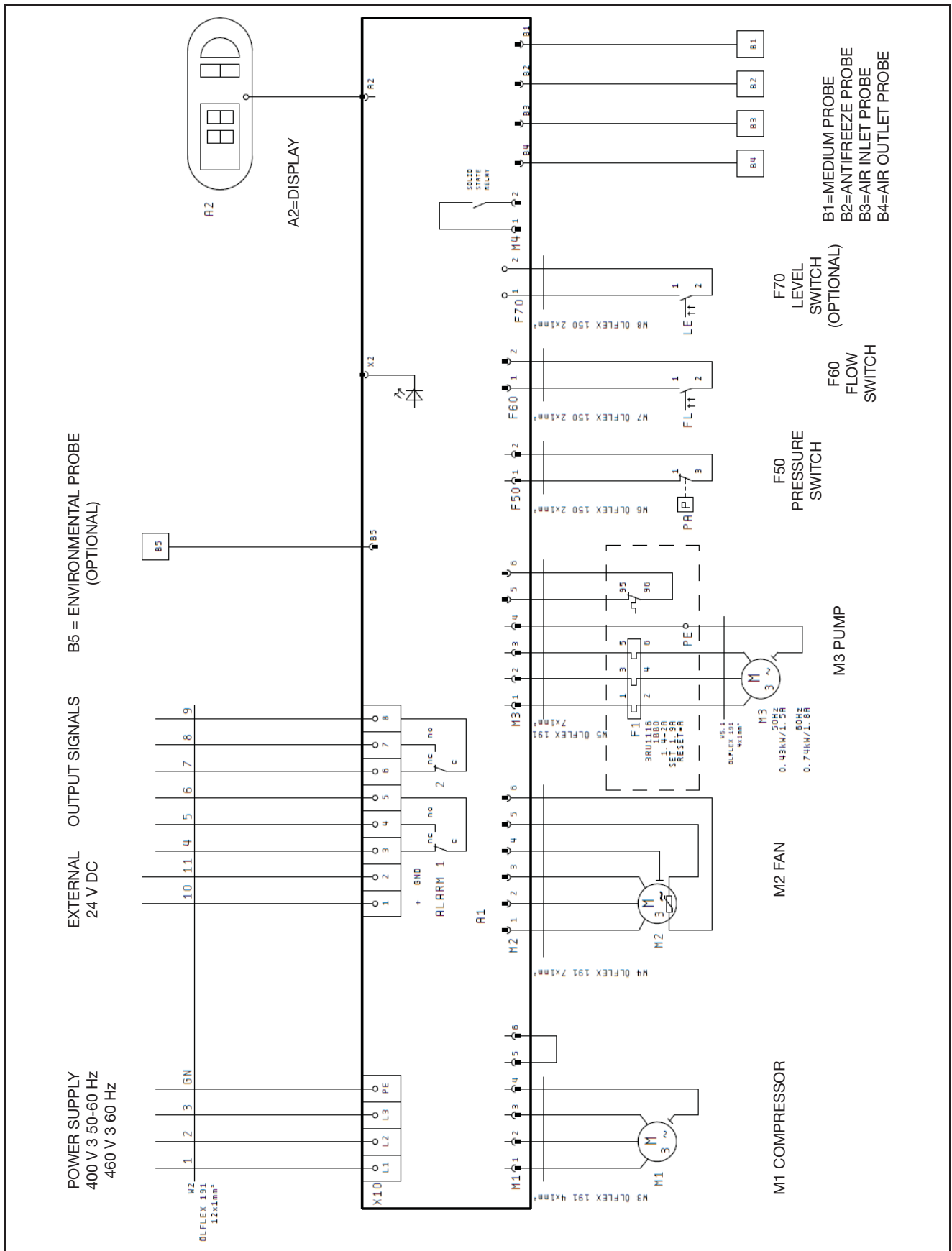

Fig. 78: Type 3360.470

12.3 Spare parts

Spare parts may be ordered directly from the Rittal web-site:

– http://www.rittal.com/com_en/spare_parts

- Select the model number of your chiller and click on "continue".



Note:

The components used are Rittal-specific components. We recommend using only original Rittal spare parts to ensure the guaranteed unit properties (output).

Types 3318.600, 3318.610, 3319.600 and 3319.610

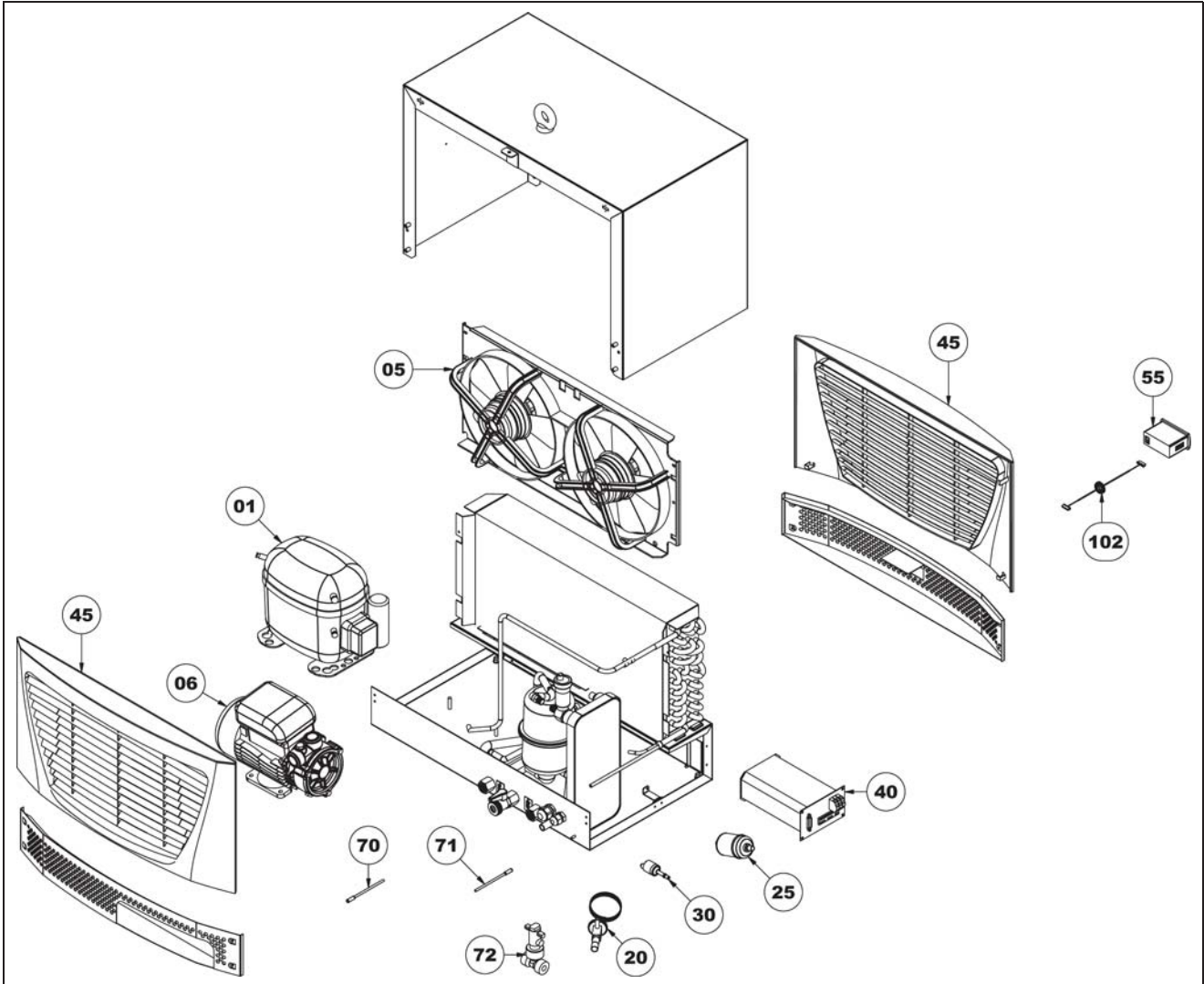

Fig. 79: Spare parts drawing for types 3318.600, 3318.610, 3319.600 and 3319.610

Key

- | | | | |
|----|--------------------|-----|----------------------|
| 1 | Compressor | 72 | Flow meter |
| 5 | Radial fan | 92 | Plate heat exchanger |
| 6 | Pump | 96 | Tank |
| 15 | Accessories bag | 100 | Condenser |
| 20 | Expansion valve | 102 | Display cable |
| 25 | Dryer | | |
| 30 | Pressostat | | |
| 40 | Controller | | |
| 45 | Grille | | |
| 46 | Grille | | |
| 50 | Cover | | |
| 55 | Display | | |
| 70 | Temperature sensor | | |
| 71 | Temperature sensor | | |

Types 3320.600, 3334.600 and 3334.660

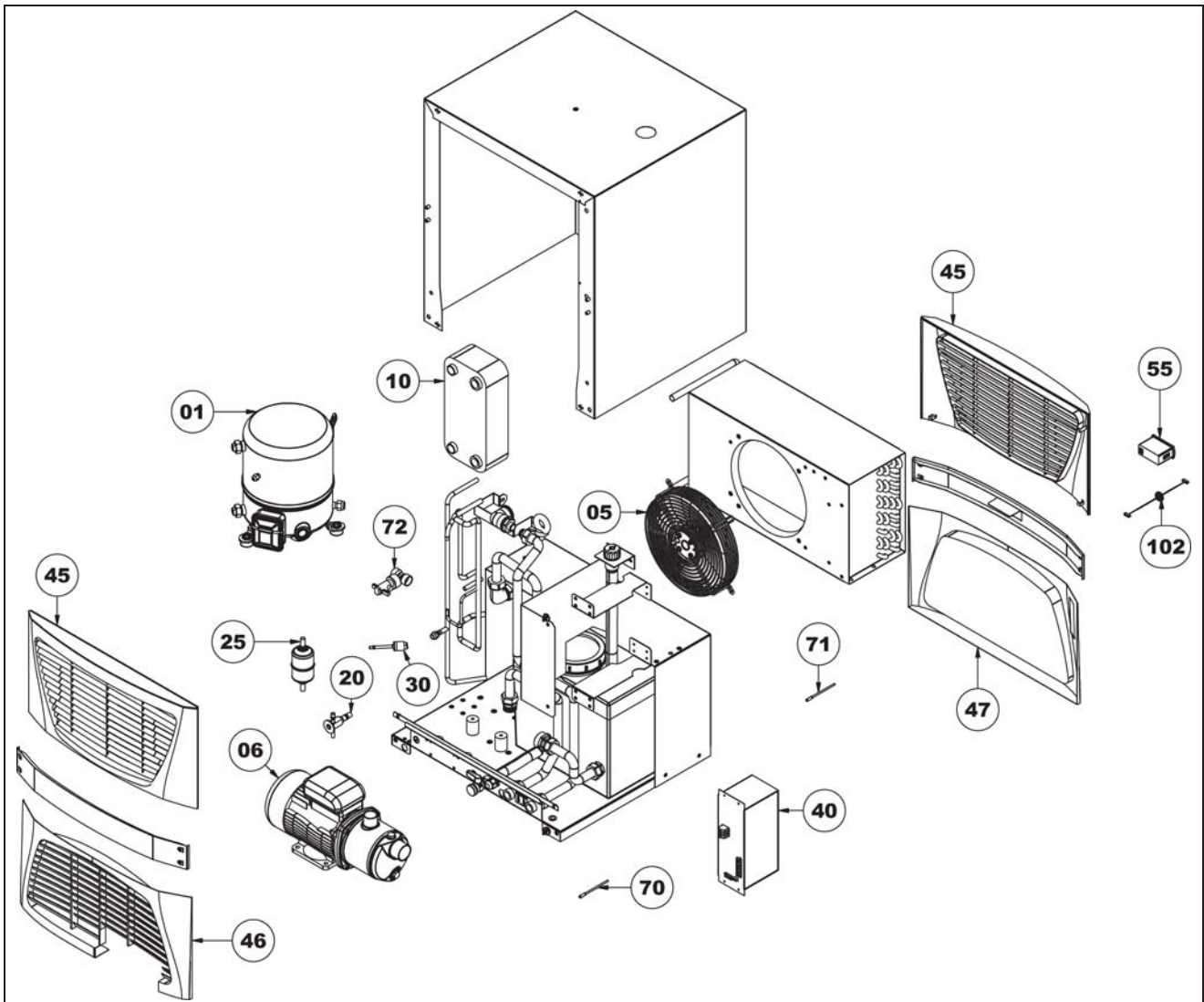

Fig. 80: Spare parts drawing for types 3320.600, 3334.600 und 3334.660

Key

- 1 Compressor
- 5 Radial fan
- 6 Pump
- 15 Accessories bag
- 20 Expansion valve
- 25 Dryer
- 30 Pressostat
- 40 Controller
- 45 Grille
- 46 Grille
- 50 Cover
- 55 Display
- 70 Temperature sensor
- 71 Temperature sensor
- 72 Flow meter
- 92 Plate heat exchanger
- 96 Tank
- 100 Condenser
- 102 Display cable

Type 3360.100

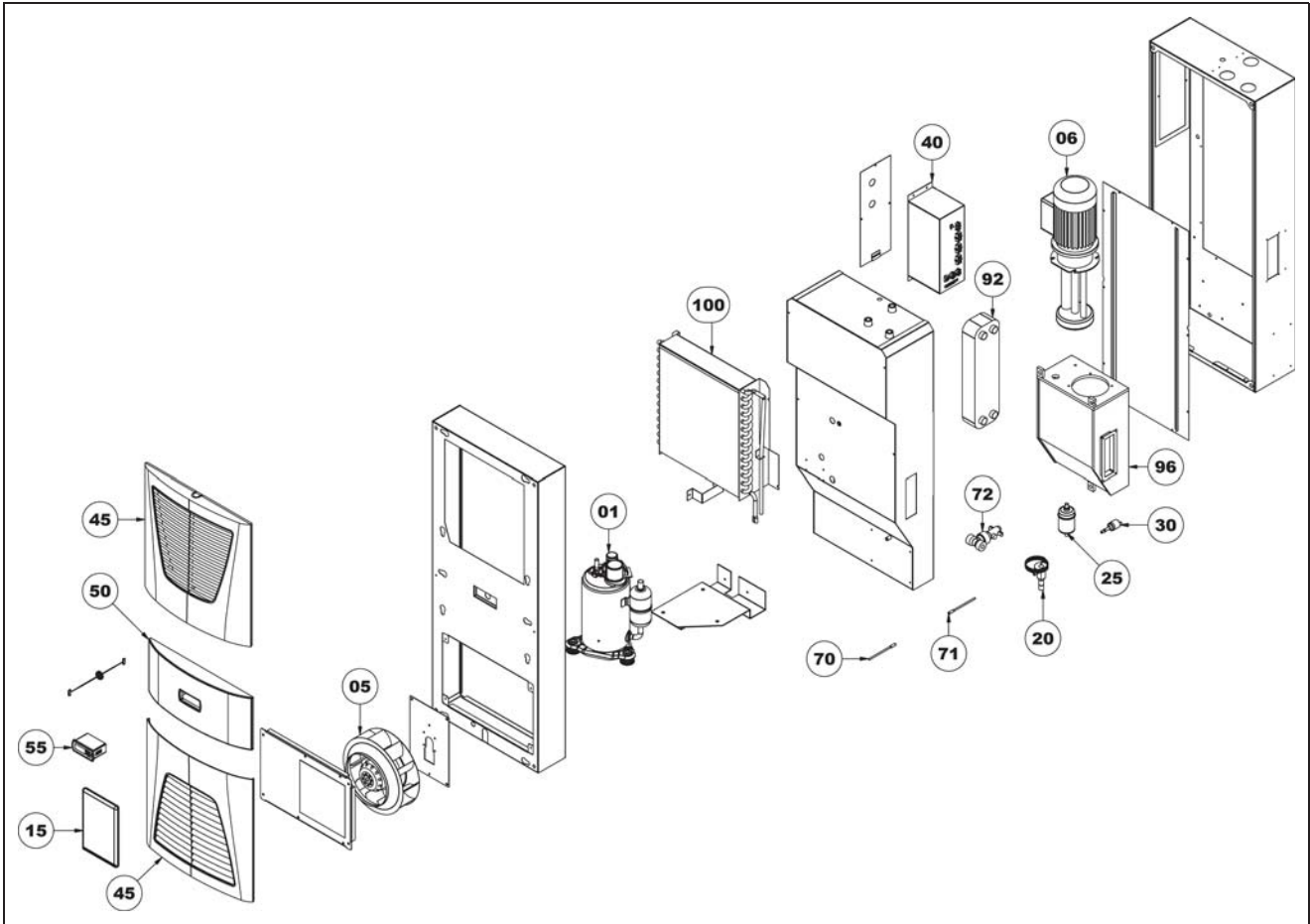

Fig. 81: Spare parts drawing for type 3360.100

Key

- 1 Compressor
- 5 Radial fan
- 6 Pump
- 15 Accessories bag
- 20 Expansion valve
- 25 Dryer
- 30 Pressostat
- 40 Controller
- 45 Grille
- 46 Grille
- 50 Cover
- 55 Display
- 70 Temperature sensor
- 71 Temperature sensor
- 72 Flow meter
- 92 Plate heat exchanger
- 96 Tank
- 100 Condenser
- 102 Display cable

Type 3360.250

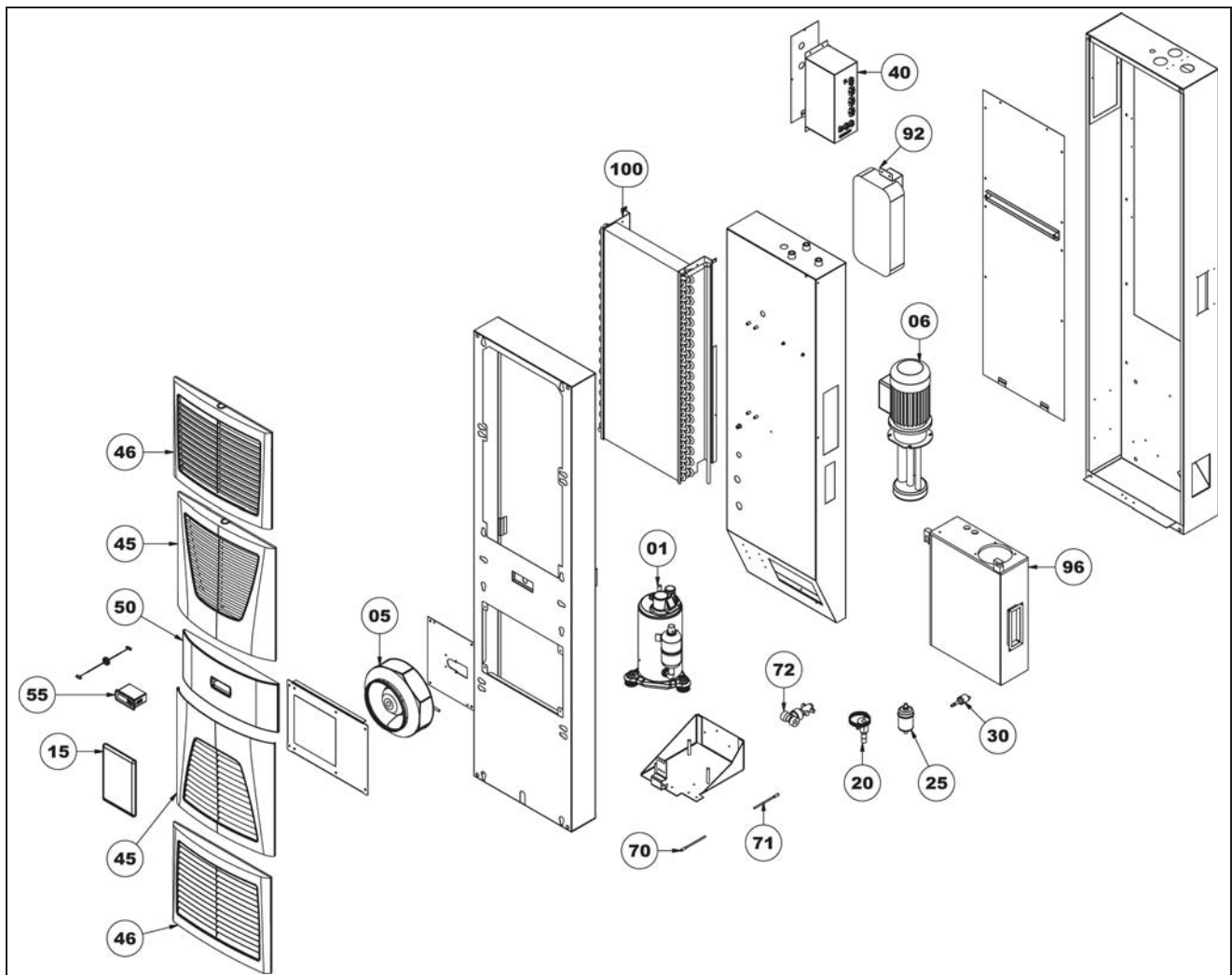

Fig. 82: Spare parts drawing for type 3360.250

Key

- 1 Compressor
- 5 Radial fan
- 6 Pump
- 15 Accessories bag
- 20 Expansion valve
- 25 Dryer
- 30 Pressostat
- 40 Controller
- 45 Grille
- 46 Grille
- 50 Cover
- 55 Display
- 70 Temperature sensor
- 71 Temperature sensor
- 72 Flow meter
- 92 Plate heat exchanger
- 96 Tank
- 100 Condenser
- 102 Display cable

12 Appendix

EN

12.4 Technical specifications

Types 3318.600, 3318.610 and 3319.600, 3319.610

Designation	Unit	Model No.			
		3318.600	3318.610	3319.600	3319.610
Rated voltage	V	230, 1~	230, 1~	230, 1~	230, 1~
Rated frequency	Hz	50/60	50/60	50/60	50/60
Rated current	A	5.1/5.6	5.1/5.6	5.7/5.6	5.7/5.6
Starting current	A	9.6/12	9.6/12	11.9/14.9	11.9/14.9
Rated power input	kW	0.69/0.80	0.69/0.80	0.86/0.99	0.86/0.99
Total cooling capacity at: $T_w = 18^\circ\text{C}$, $T_a = 32^\circ\text{C}$	kW	0.96/1.07	0.96/1.07	1.49/1.66	1.49/1.66
Total cooling capacity at: $T_w = 10^\circ\text{C}$, $T_a = 32^\circ\text{C}$	kW	0.78/0.87	0.78/0.87	1.20/1.33	1.20/1.33
Total cooling capacity at: $T_w = 18^\circ\text{C}$, $T_a = 35^\circ\text{C}$ to DIN EN 14511	kW	0.98/1.07	0.98/1.07	1.47/1.66	1.47/1.66
Refrigerant – Type – Charge	– g	R134a 975	R134a 975	R134a 975	R134a 975
EER-rated (Energy efficiency ratio)		1.38/1.33	1.38/1.33	1.71/1.67	1.71/1.67
Pressure P_S	bar	HP 25 LP 11	HP 25 LP 11	HP 25 LP 11	HP 25 LP 11
Temperature range	$^\circ\text{C}$	+15...+43	+15...+43	+15...+43	+15...+43
Temperature range of the cooling medium	$^\circ\text{C}$	+10...+30	+10...+30	+10...+30	+10...+30
Fluid pressure range	bar	0.2...3	0.2...3.5	0.2...3/0.2...4	0.2...3/0.2...4
Tank volume	l	–	2.5	–	2.5
Sound power level* EN 12102	dB (A)	62	62	62	62
IP class EN 60529		IP 44	IP 44	IP 44	IP 44
Water connections		2 x 1/2" internal thread	2 x 1/2" internal thread	2 x 1/2" internal thread	2 x 1/2" internal thread
Weight / operating weight	kg	48/50.5	48/50.5	51/53.5	51/53.5
GWP (R134a)	-	1430	1430	1430	1430
CO2e	t	1,394	1,394	1,394	1,394

Tab. 21: Technical specifications for 3318.600, 3318.610 and 3319.600, 3319.610

* Measured in free field at a distance of 1 m and at an height of 1 m from ground

Types 3320.600, 3334.600

Description	Unit	Model No.			
		3320.600		3334.600	
Rated voltage	V	400, 3~	460, 3~	400, 3~	460, 3~
Rated frequency	Hz	50/60	60	50/60	60
Rated current	A	4.05/4.35	4.35	5.6/5.9	6.15
Starting current	A	14/17.1	14	24	24
Rated power input	kW	2.03/2.39	2.67	2.88/3.24	4.02
Total cooling capacity at: $T_w = 18^\circ\text{C}$, $T_a = 32^\circ\text{C}$	kW	3.00/3.40	3.40	4.50/5.40	5.40
Total cooling capacity at: $T_w = 10^\circ\text{C}$, $T_a = 32^\circ\text{C}$	kW	2.65/3.00	3.00	3.90/4.70	4.70
Total cooling capacity at: $T_w = 18^\circ\text{C}$, $T_a = 35^\circ\text{C}$ to DIN EN 14511	kW	2.59/3.33	3.33	4.48/5.28	5.28
Refrigerant – Type – Charge	– g	R134a 1200		R134a 1500	
EER-rated (Energy efficiency ratio)		1.48/1.42	1.27	1.56/1.67	1.34
Pressure P_S	bar	HP 25 LP 11		HP 25 LP 11	
Temperature range	$^\circ\text{C}$	+15...+43		+15...+43	
Temperature range of the cooling medium	$^\circ\text{C}$	+10...+30		+10...+30	
Fluid pressure range	bar	1.45...3.2 2.25...5.4	2.25...5.4	1.45...3.2 2.25...5.4	2.25...5.4
Tank volume	l	30		30	
Sound power level* EN 12102	dB (A)	68		68	
IP class EN 60529		IP 44		IP 44	
Water connections		2 x 1/2" internal thread		2 x 1/2" internal thread	
Weight / operating weight	kg	88/118		94/124	
GWP (R134a)	-	1430		1430	
CO₂e	t	1,716		1,716	

Tab. 22: Technical specifications for 3320.600, 3334.600

* Measured in free field at a distance of 1 m and at an height of 1 m from ground

12 Appendix

EN

Type 3334.660

Description	Unit	Model No.	
		3334.660	
Rated voltage	V	400, 3~	460, 3~
Rated frequency	Hz	50/60	60
Rated current	A	8.2/8.5	8
Starting current	A	40/40	40
Rated power input	kW	3.98/4.37	5.32
Total cooling capacity at: T _w = 18°C, T _a = 32°C	kW	6.06/6.62	6.62
Total cooling capacity at: T _w = 10°C, T _a = 32°C	kW	4.80/5.15	5.15
Total cooling capacity at: T _w = 18°C, T _a = 35°C	kW	5.93/6.48	6.48
to DIN EN 14511			
Refrigerant	-	R134a	
- Type	-	2200	
- Charge	g		
EER-rated (Energy efficiency ratio)		1.52/1.52	1.24
Pressure P _S	bar	HP 25 LP 11	
Temperature range	°C	+15...+43	
Temperature range of the cooling medium	°C	+10...+30	
Fluid pressure range	bar	1.45...3.2 2.25...5.4	2.25...5.4
Tank volume	l	30	
Sound power level* EN 12102	dB (A)	69	
IP class EN 60529		IP 44	
Water connections		2 x 1/2" internal thread	
Weight / operating weight	kg	125/155	
GWP (R134a)	-	1430	
CO2e	t	3,146	

Tab. 23: Technical specifications for 3334.660

* Measured in free field at a distance of 1 m and at an height of 1 m from ground

Type 3360.100

Description	Unit	Model No.	
		3360.100	
Rated voltage	V	400, 3~	460, 3~
Rated frequency	Hz	50/60	60
Rated current	A	4.2/4.0	4
Starting current	A	15.6/15.6	15.6
Rated power input	kW	1.16/1.21	1.21
Total cooling capacity at: $T_w = 18^\circ\text{C}$, $T_a = 32^\circ\text{C}$	kW	1.00/1.10	1.10
Total cooling capacity at: $T_w = 10^\circ\text{C}$, $T_a = 32^\circ\text{C}$	kW	0.80/0.90	0.90
Total cooling capacity at: $T_w = 18^\circ\text{C}$, $T_a = 35^\circ\text{C}$ to DIN EN 14511	kW	0.98/1.07	1.07
Refrigerant – Type – Charge	– g	R134a 500	
EER-rated (Energy efficiency ratio)		0.86/0.90	0.90
Pressure P_S	bar	HP 25 LP 11	
Temperature range	$^\circ\text{C}$	+15...+43	
Temperature range of the cooling medium	$^\circ\text{C}$	+10...+30	
Fluid pressure range	bar	0.5...2.3 1...3.2	1...3.2
Tank volume	l	5	
Sound power level* EN 12102	dB (A)	68	
IP class EN 60529		IP 44	
Water connections		Quick-release coupling	
Weight / operating weight	kg	47/52	
GWP (R134a)	-	1430	
CO2e	t	0,715	

Tab. 24: Technical specifications for 3360.100

* Measured in free field at a distance of 1 m and at an height of 1 m from ground

12 Appendix

EN

Type 3360.250

Description	Unit	Model No.	
		3360.250	
Rated voltage	V	400, 3~	460, 3~
Rated frequency	Hz	50/60	60
Rated current	A	5.5/5.6	5.6
Starting current	A	15.6/16.7	16.7
Rated power input	kW	2.20/2.50	2.20
Total cooling capacity at: $T_w = 18^\circ\text{C}$, $T_a = 32^\circ\text{C}$	kW	2.50/2.74	2.74
Total cooling capacity at: $T_w = 10^\circ\text{C}$, $T_a = 32^\circ\text{C}$	kW	2.10/2.30	2.30
Total cooling capacity at: $T_w = 18^\circ\text{C}$, $T_a = 35^\circ\text{C}$ to DIN EN 14511	kW	2.44/2.74	2.74
Refrigerant – Type – Charge	– g	R134a 950	
EER-rated (Energy efficiency ratio)		1.13/1.10	1.10
Pressure P_S	bar	HP 25 LP 11	
Temperature range	$^\circ\text{C}$	+15...+43	
Temperature range of the cooling medium	$^\circ\text{C}$	+10...+30	
Fluid pressure range	bar	0.5...2.3 1...3.2	1...3.2
Tank volume	l	10	
Sound power level* EN 12102	dB (A)	68	
IP class EN 60529		IP 44	
Water connections		Quick-release coupling	
Weight / operating weight	kg	78/88	
GWP (R134a)	-	1430	
CO2e	t	1,359	

Tab. 25: Technical specifications for 3360.250

* Measured in free field at a distance of 1 m and at an height of 1 m from ground

Type 3360.470

Description	Unit	Model No.	
		3360.470	
Rated voltage	V	400, 3~	460, 3~
Rated frequency	Hz	50/60	60
Rated current	A	4.8/5.3	5.3
Starting current	A	17/17	17
Rated power input	kW	2.13/3.00	3.00
Total cooling capacity at: $T_w = 18^\circ\text{C}$, $T_a = 32^\circ\text{C}$	kW	4.00/4.40	4.40
Total cooling capacity at: $T_w = 10^\circ\text{C}$, $T_a = 32^\circ\text{C}$	kW	3.3/3.7	3.7
Total cooling capacity at: $T_w = 18^\circ\text{C}$, $T_a = 35^\circ\text{C}$ to DIN EN 14511	kW	3.8/4.3	4.3
Refrigerant – Type – Charge	– g	R134a 3000	
EER-rated (Energy efficiency ratio)		1.87/1.46	1.46
Pressure P_S	bar	HP 25 LP 11	
Temperature range	$^\circ\text{C}$	+15...+43	
Temperature range of the cooling medium	$^\circ\text{C}$	+10...+30	
Fluid pressure range	bar	1.5...3.5 2.5...5.2	2.5...5.2
Tank volume	l	15	
Sound power level* EN 12102	dB (A)	68	
IP class EN 60529		IP 44	
Water connections		¾" internal thread	
Weight / operating weight	kg	99/114	
GWP (R134a)	-	1430	
CO₂e	t	4,290	

Tab. 26: Technical specifications for 3360.470

* Measured in free field at a distance of 1 m and at an height of 1 m from ground

Rittal – The System.

Faster – better – everywhere.

- Enclosures
- Power Distribution
- Climate Control
- IT Infrastructure
- Software & Services

7th edition 05.2016 / ID no. 925564

You can find the contact details of all Rittal companies throughout the world here.



www.rittal.com/contact

ENCLOSURES

POWER DISTRIBUTION

CLIMATE CONTROL

IT INFRASTRUCTURE

SOFTWARE & SERVICES

FRIEDHELM LOH GROUP

